

elastic STRUCTURE + SPACE

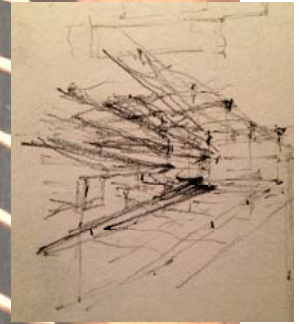

Wendell Vaughn AIA, LEED BD+C
ARCHITECTURE + PLANNING

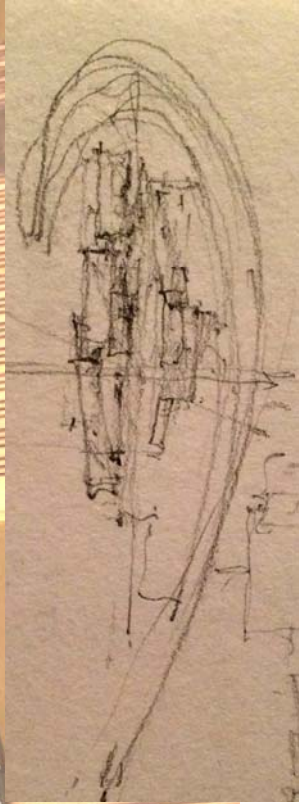
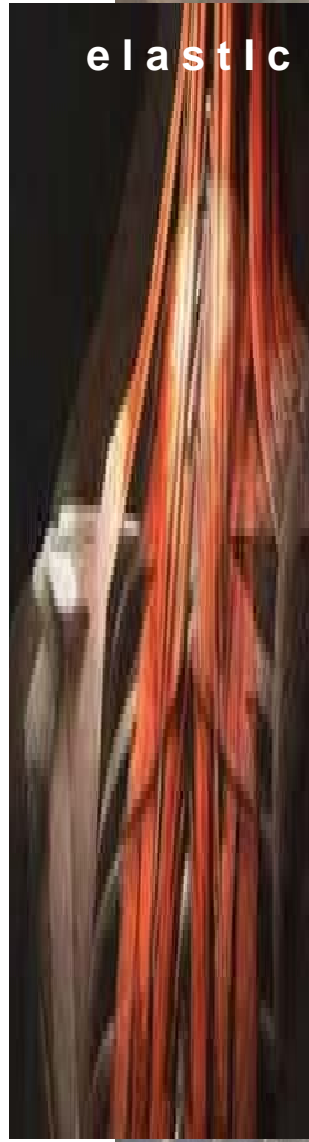

Copyright Marvel Studios

Location: [Atrisco Heritage Academy High School](#)

As Seen In: [The Avengers](#)

Nick Fury's helicopter lands at the facility.



**ATRISCO HERITAGE ACADEMY
HIGH SCHOOL, ALBUQUERQUE, NM**



on the BIG SCREEN

**WENDELL VAUGHN AIA, LEED BD+C
DESIGN PRINCIPAL
PERKINS + WILL**

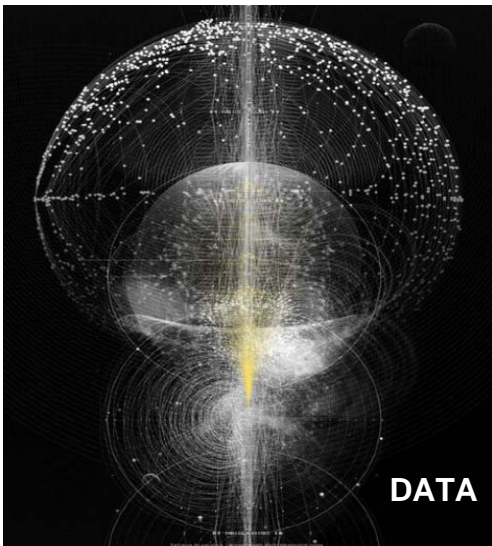

PROJECT LE³

DATA VISUALIZATION

what if

with our COLLECTIVE RESOURCES

*...WE TURN OURSELVES
INSIDE OUT*

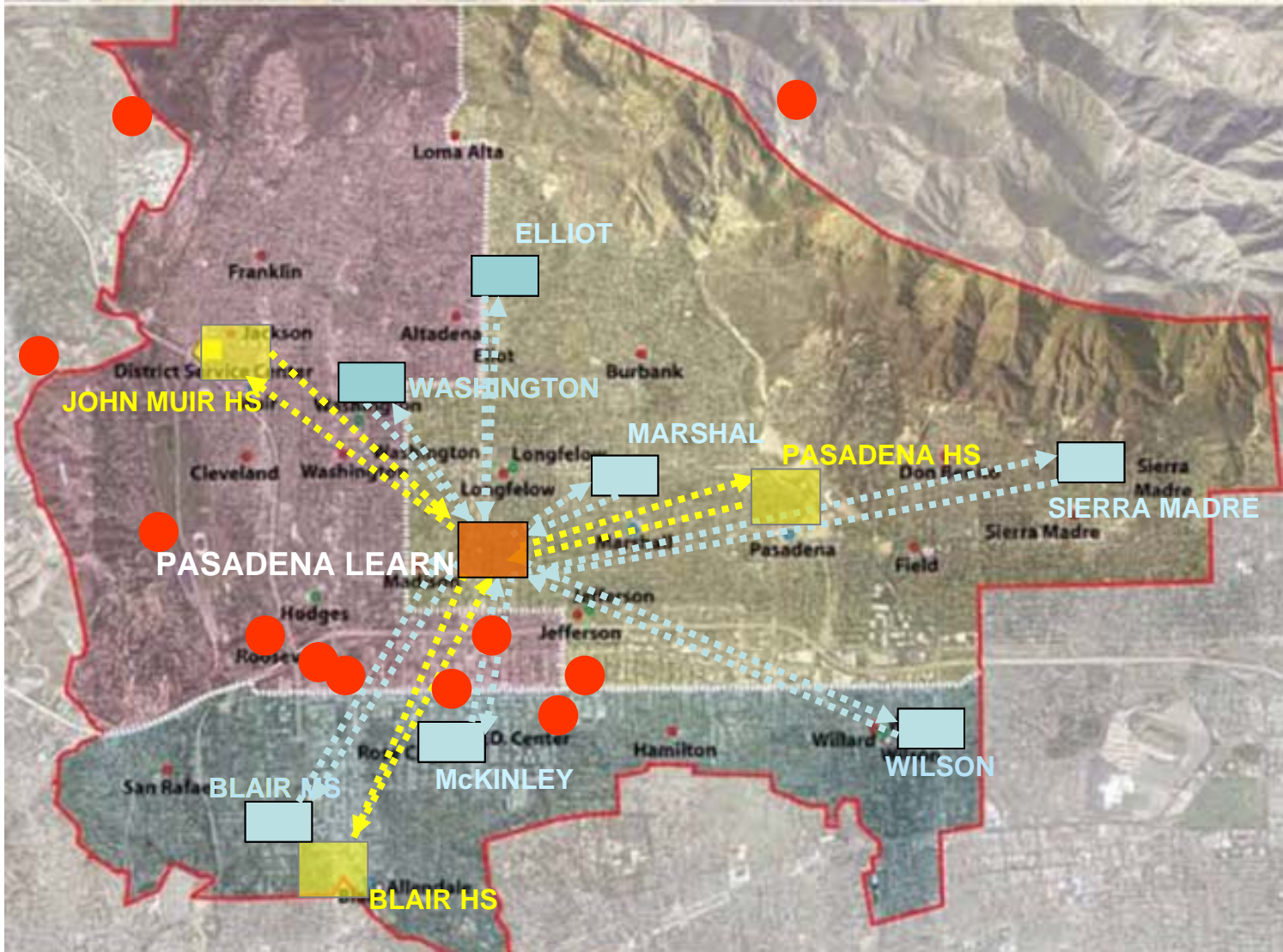

what if

our campuses serve as BLANK CANVAS with
ENVIRONMENTS
EXPERIENCES
EXPLORATION

*...WHERE STUDENTS AUTHOR
THEIR OWN SPACES*

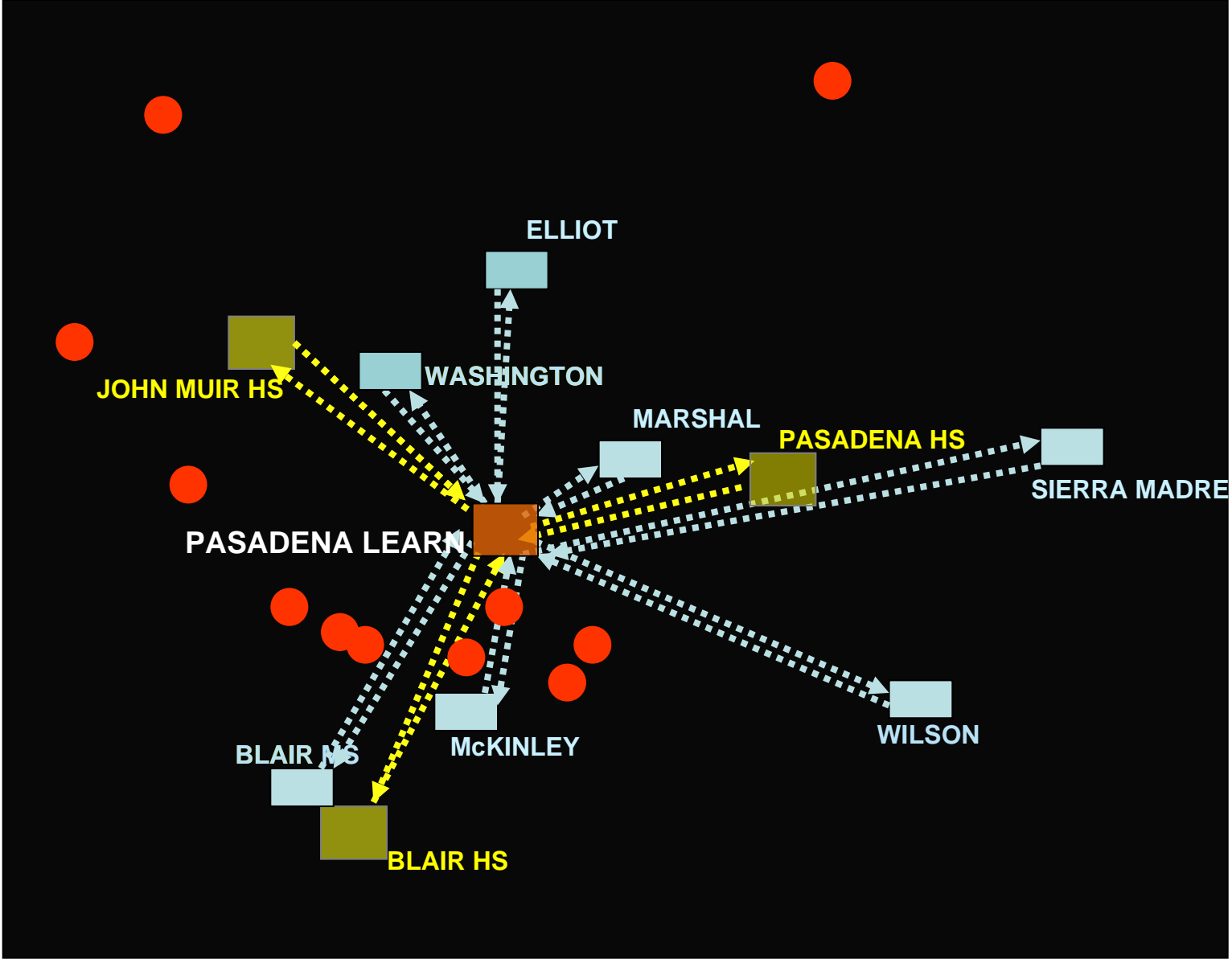

we can

provide all students within our communities the OPPORTUNITY to play....

on the WORLD STAGE ...



what if

....we **INVERT** the EQUATION

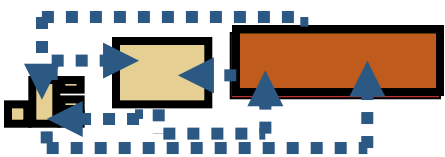
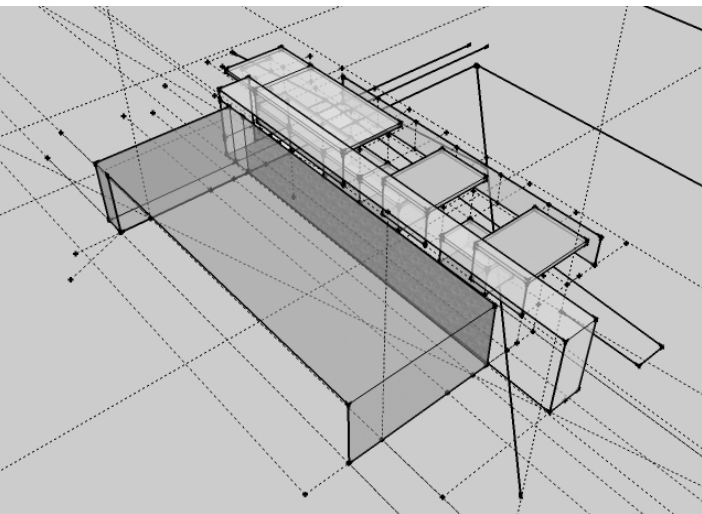
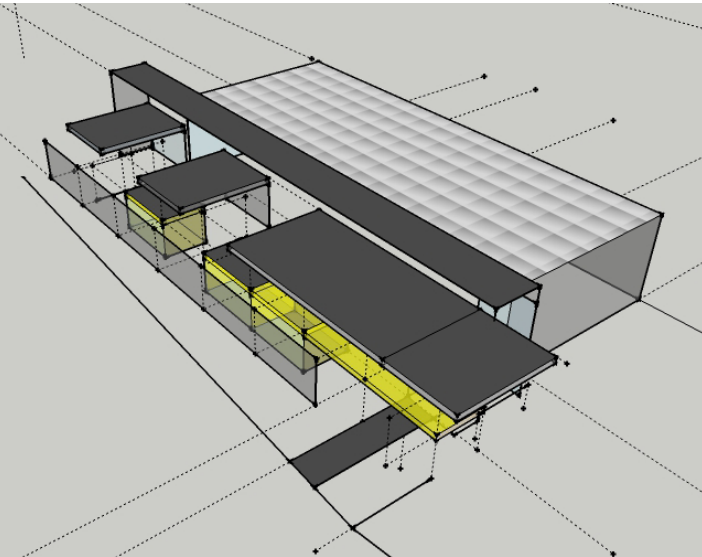

**PHASE III
NEW BUILDING CONSTRUCTION**

**PASADENA EXPLORE
JOINT-USE COMMUNITY**

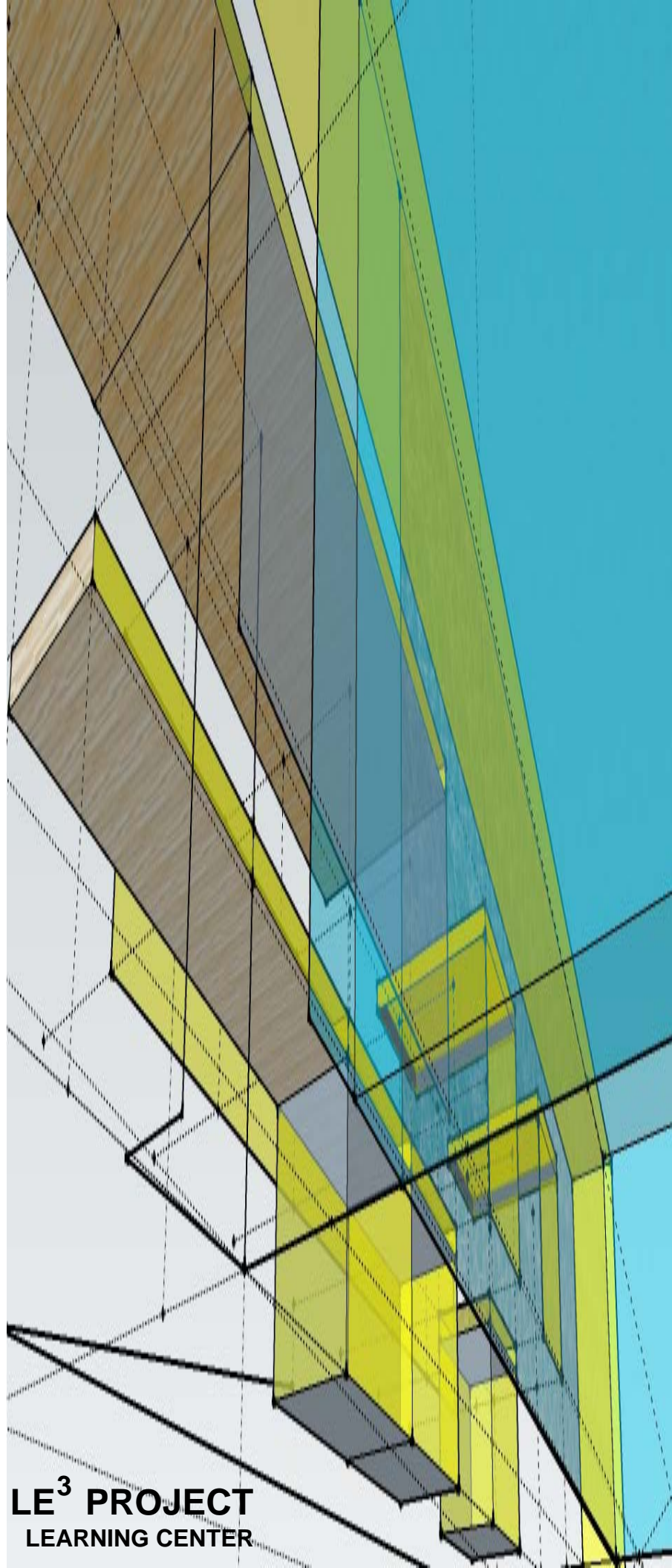

**LE³ PROJECT
LEARNING CENTER**

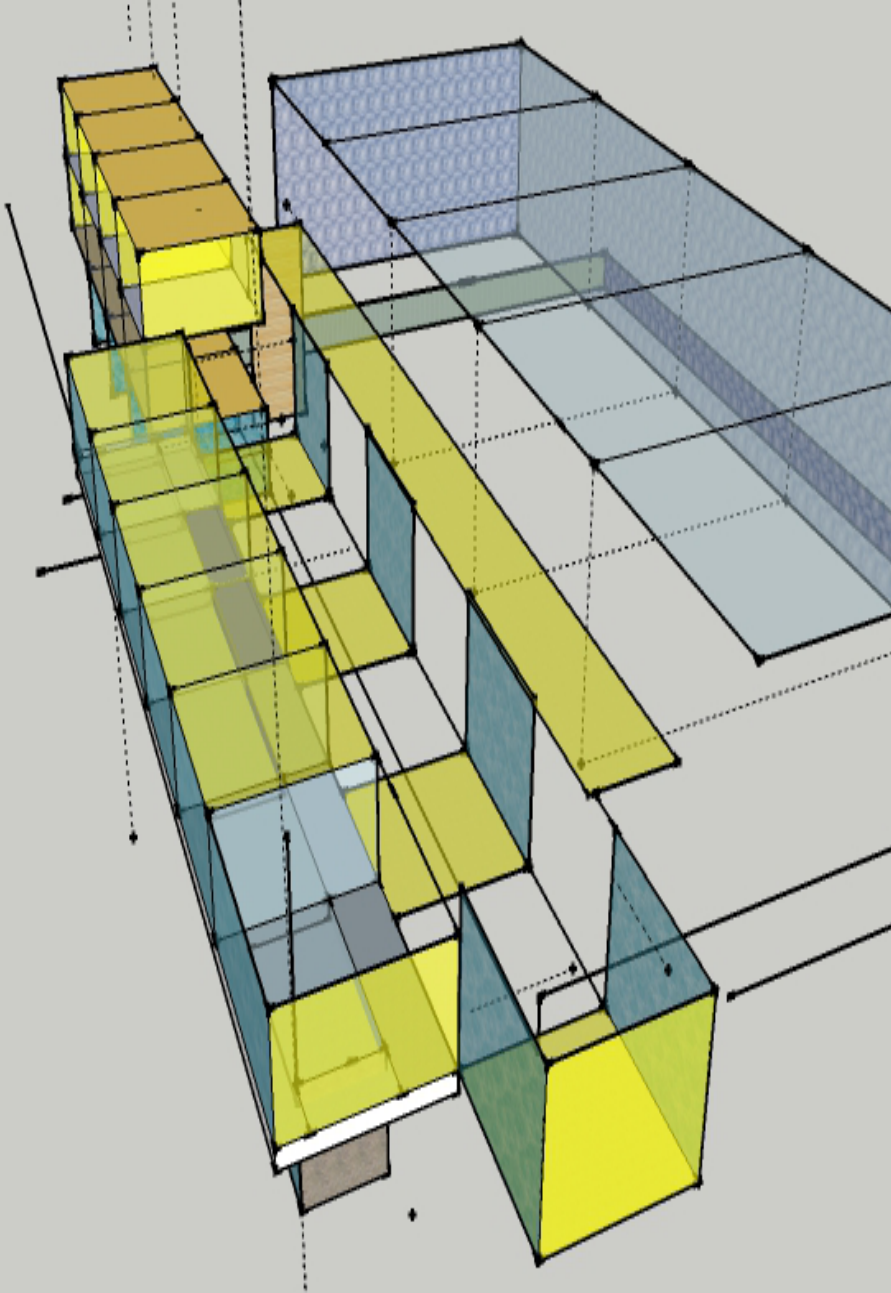

OPTION A

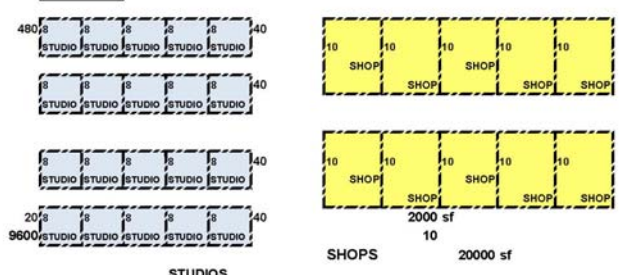

OPTION B

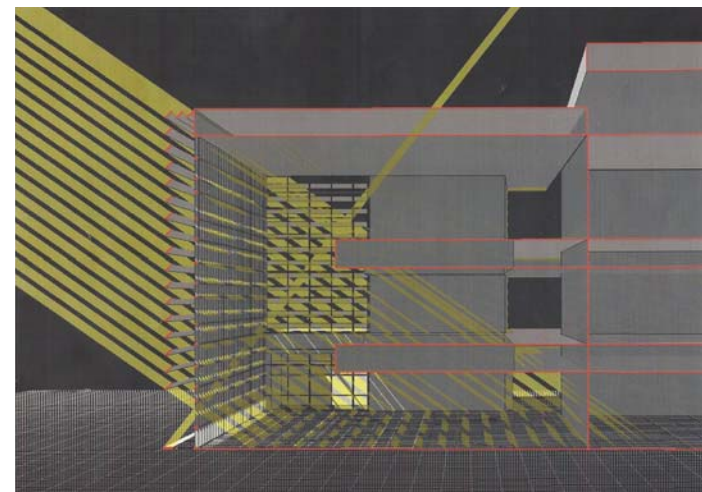
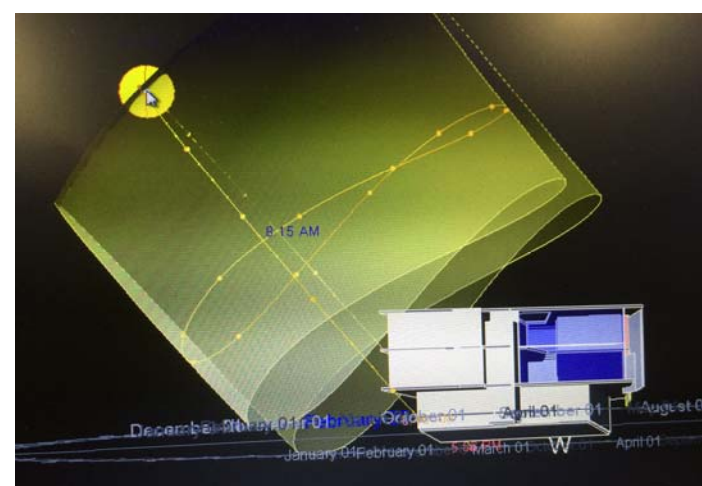
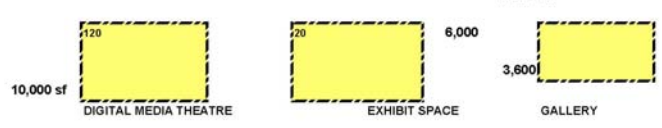
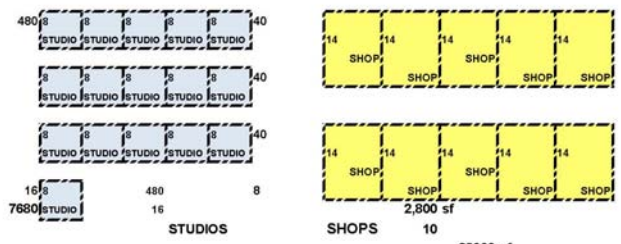

the PHYSICS of BUILDING DESIGN PERFORMANCE

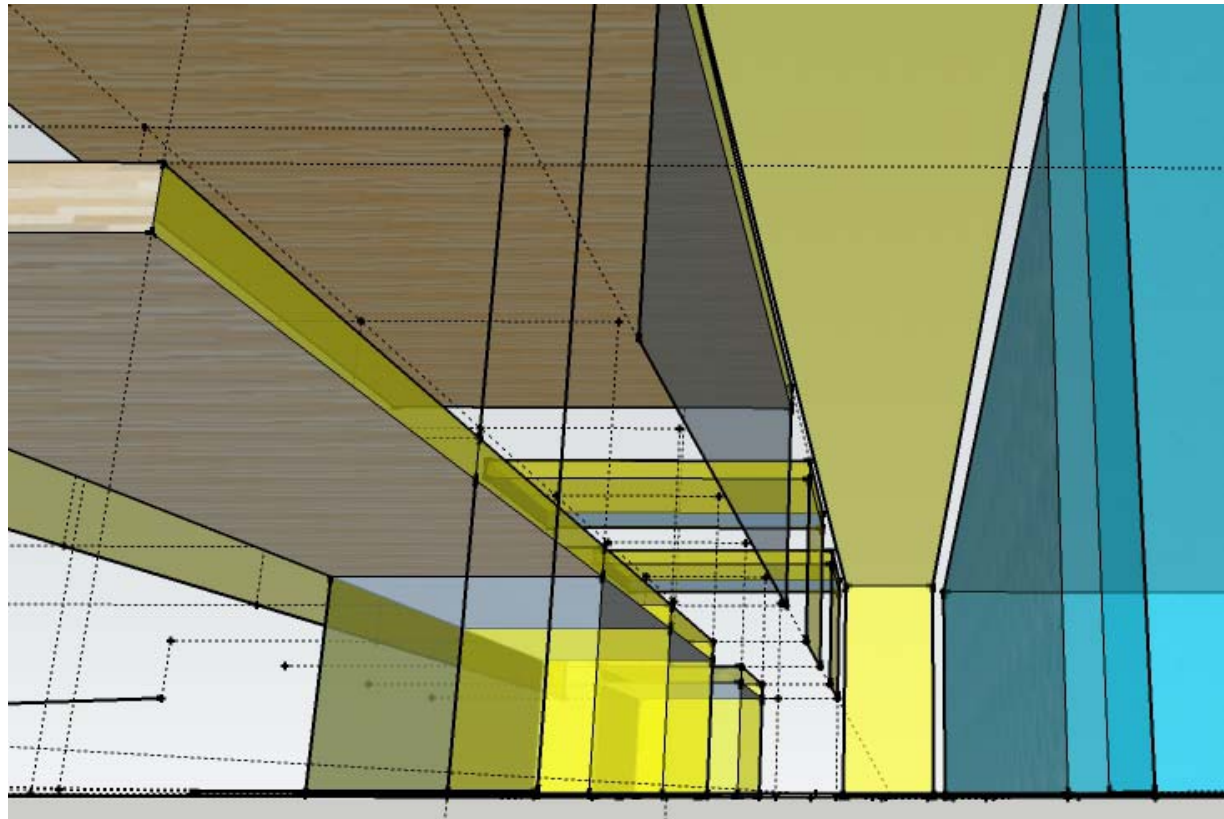
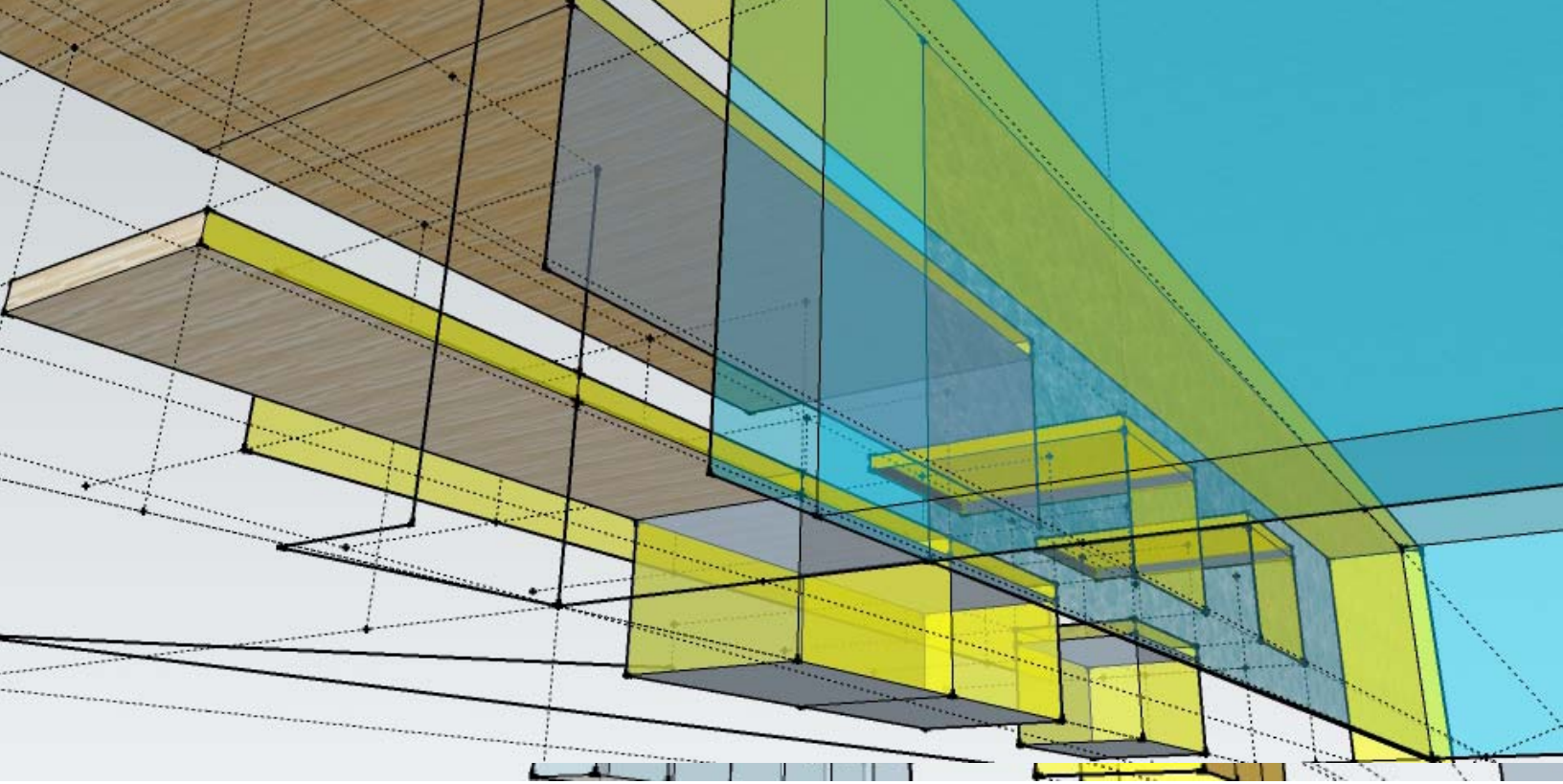

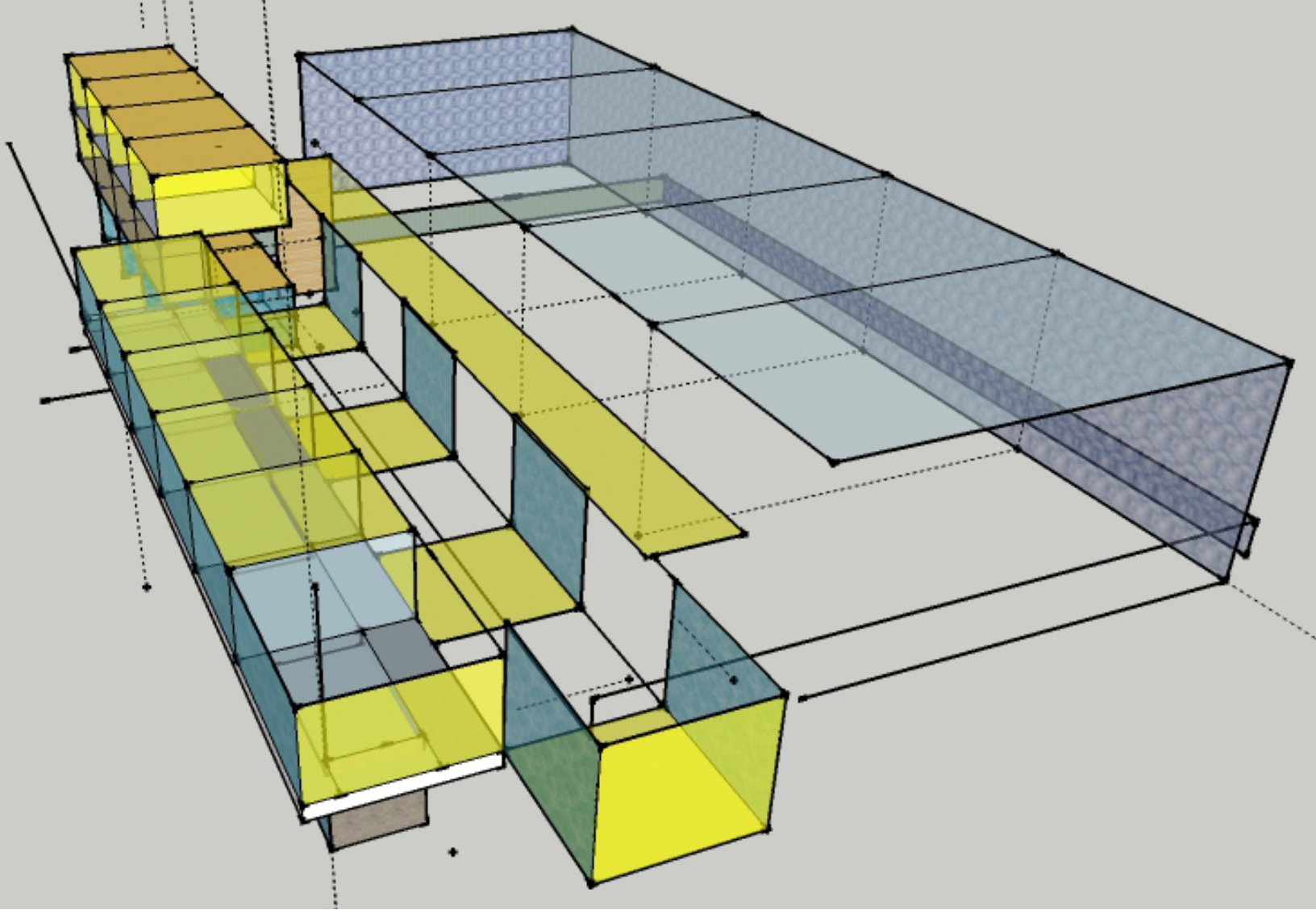

PROJECT PROGRAMING IMAGES
web-research images

” DARKSIDE of the ROOM”

INTERACTIVE SPACE

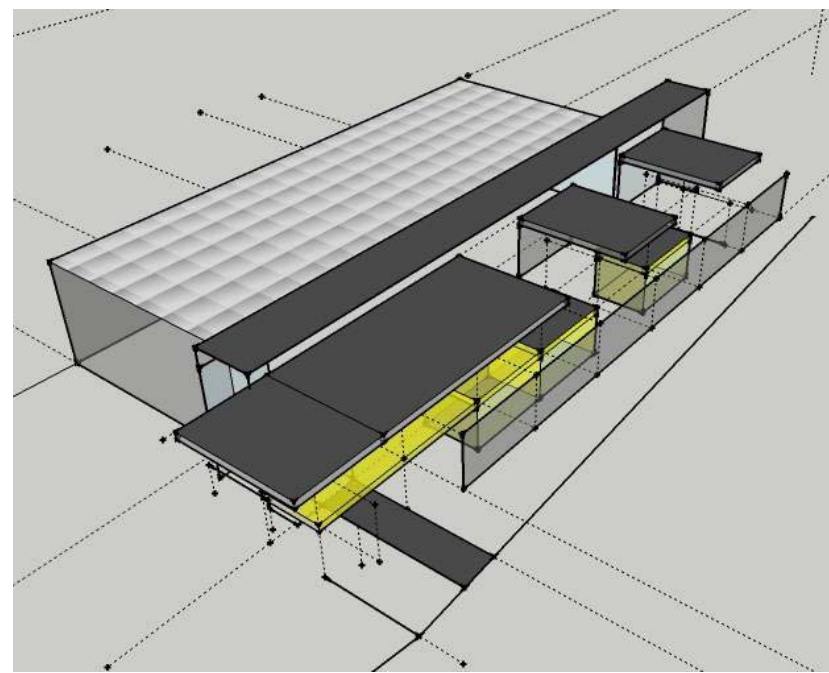
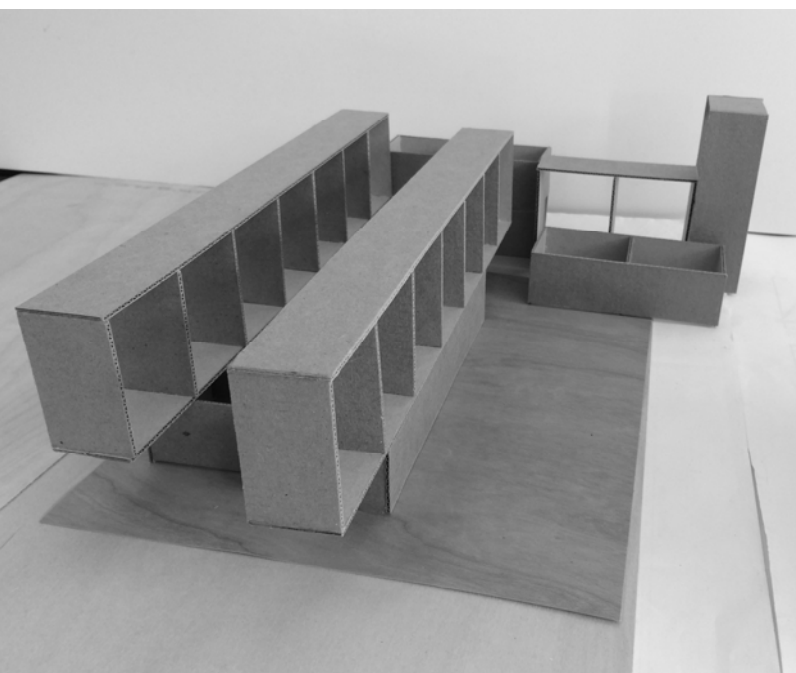

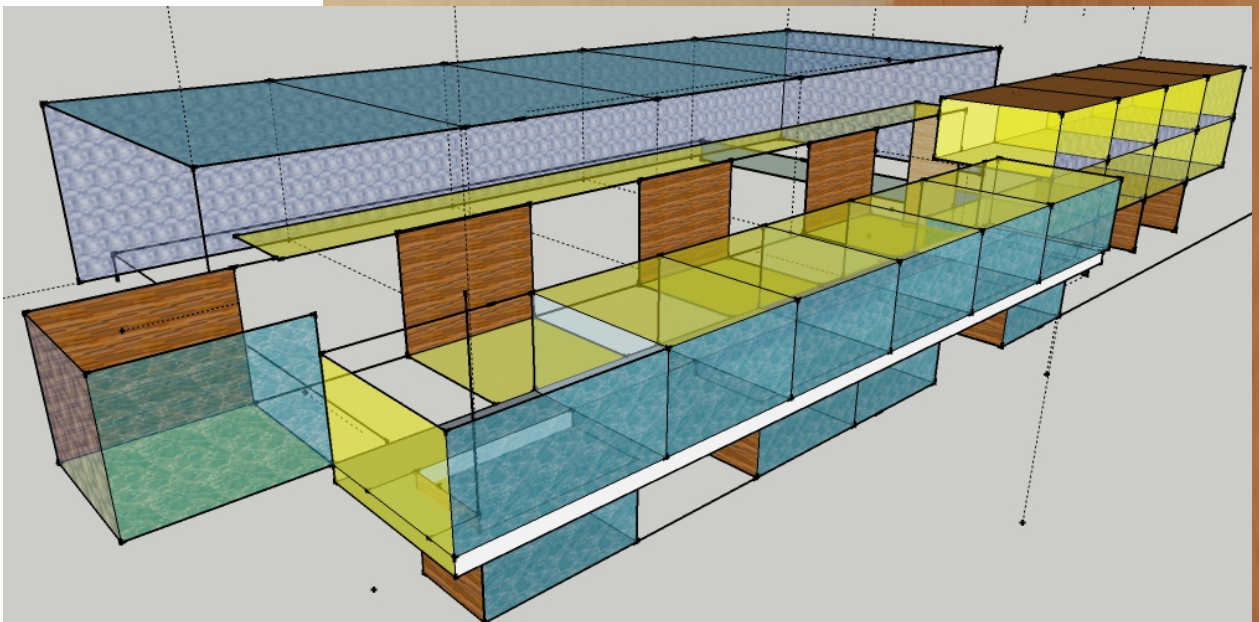
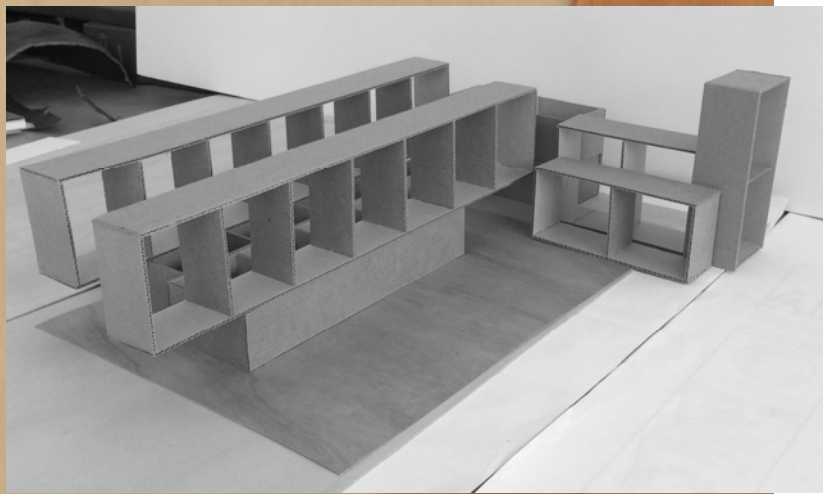
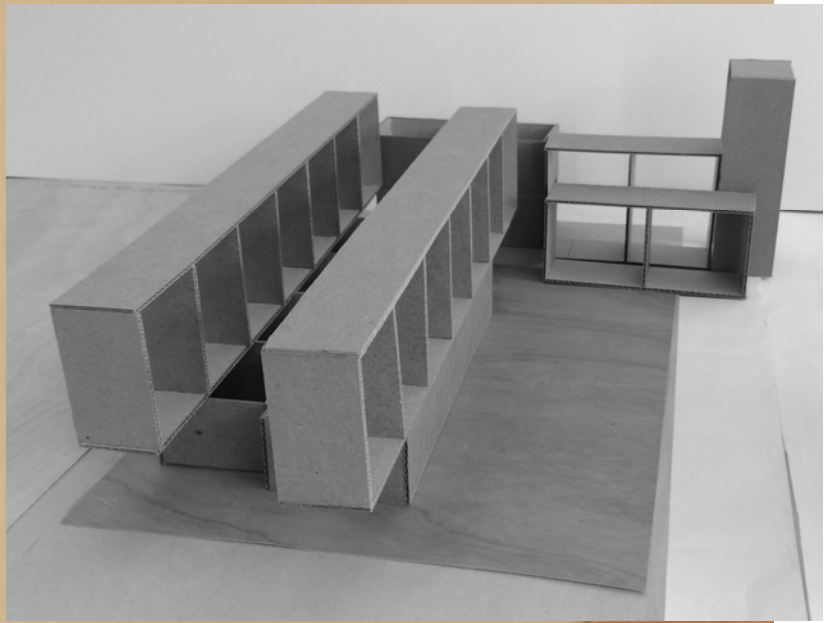

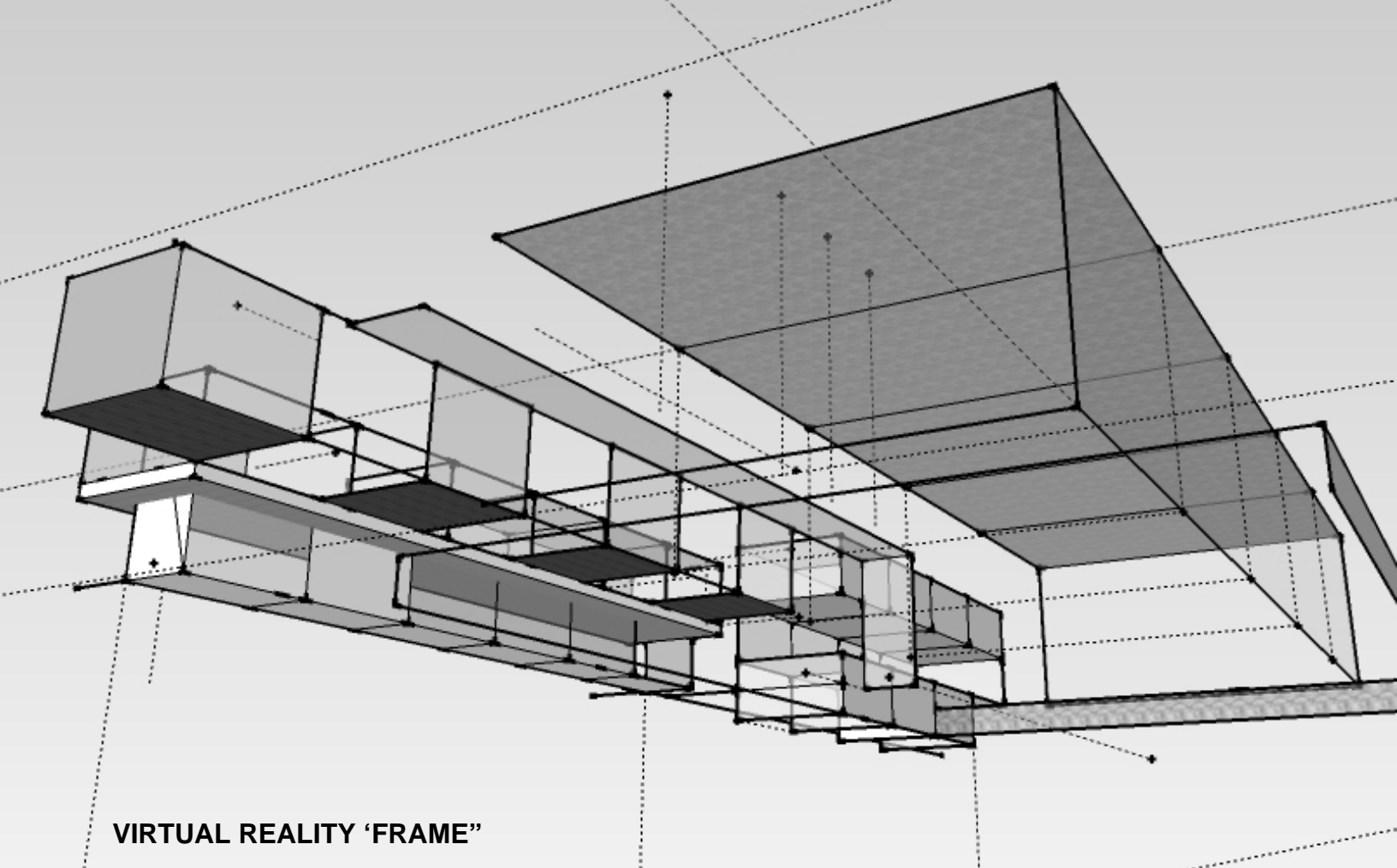

VIRTUAL REALITY 'FRAME'



“Coca Cola – 125th Year Exhibition from Antilop on Vimeo.
The SantralIstanbul is an arts and cultural complex located at the upper end of Golden Horn in the Eyüp district of Istanbul, Turkey. ...”

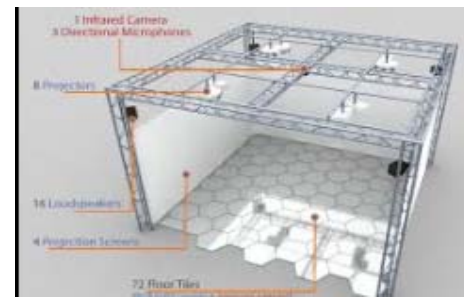

PROJECT PROGRAMING RESEARCH web- images and project photographs reflect pre—manufactured systems and equipment by others

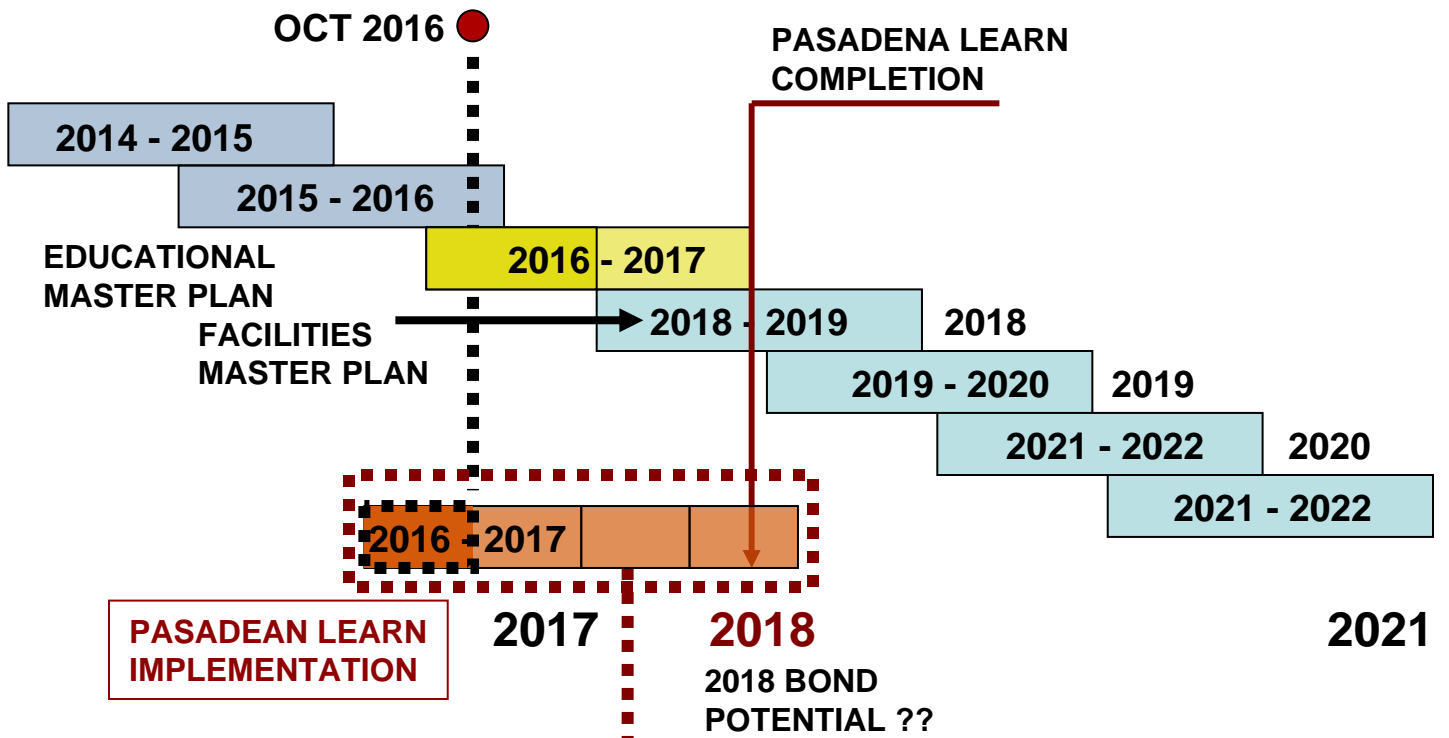

OCTOBER 2016

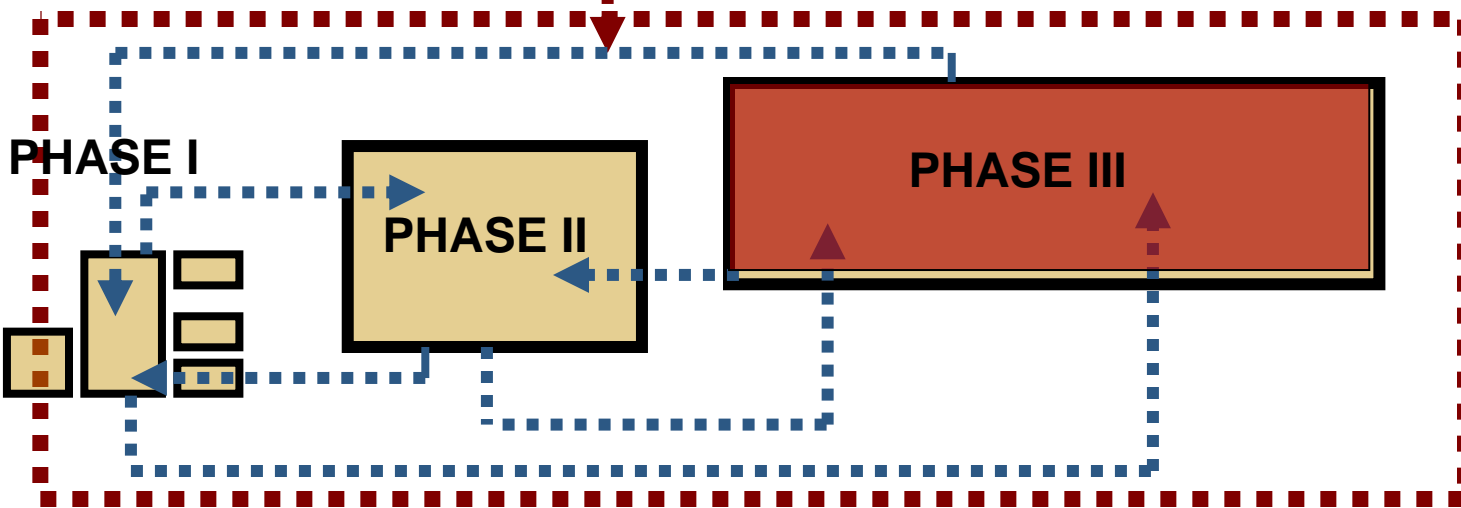

IMMEDIATE IMPLEMENTATION with a PHASED PROJECT (s) SCHEDULE

...IMPACT EVERY STUDENT and MENTOR TODAY

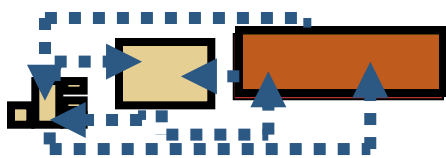

PHASED PROJECT CONSTRUCTION

< C = > LE³

< CONSTRUCTION = > MORE LEARNING

LE³ = ENVIRONMENTS
EXPERIENCES
EXPLORATION



EXISTING CAMPUSES... "NEW" STUDIOS



PROJECT PROGRAMMING IMAGES
web-research images



INVIGORATE and REVITALIZE
EXISTING "CLASSROOMS" ENVIRONMENTS
and EXPERIENCES

"GUT & PAINT"

ROLL UP the SLEEVES
IMMEDIATE IMPLEMENTATION
NO LOST GENERATIONS with "PLANNING"

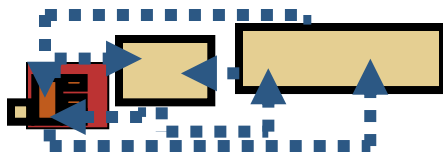

PHASE I
BUILDING REVITALIZATION

PROJECT LE³



where

**COLLABORATIVE PASADENA is INTEGRATED
within OUR COMMUNITY'S FABRIC**

**DYNAMIC DISPLAY of INTERACTIVE EDUCATIONAL
PLANNING/DESIGN**

COMMUNITY DESIGN, LEARN SHOPS

COMMUNITY EVENTS, EXHIBITS GALLERY

MEDIA EVENTS PLATFORM

PLANNING & LEARNING is ACCESSIBLE

***CONNECT to COMMUNITY
from the INSIDE - OUT***

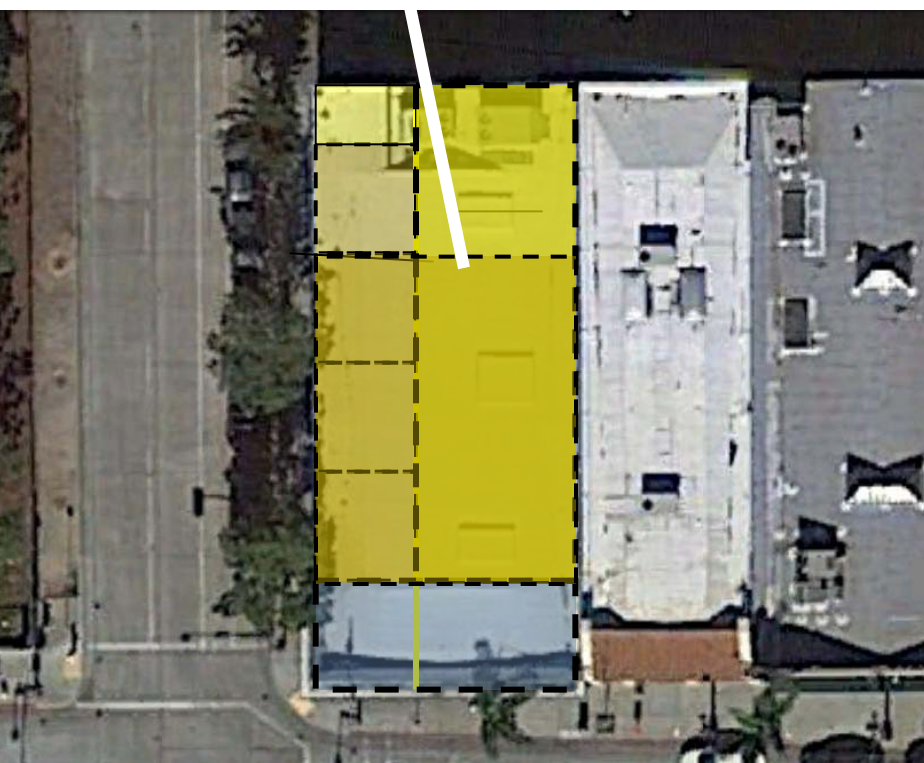
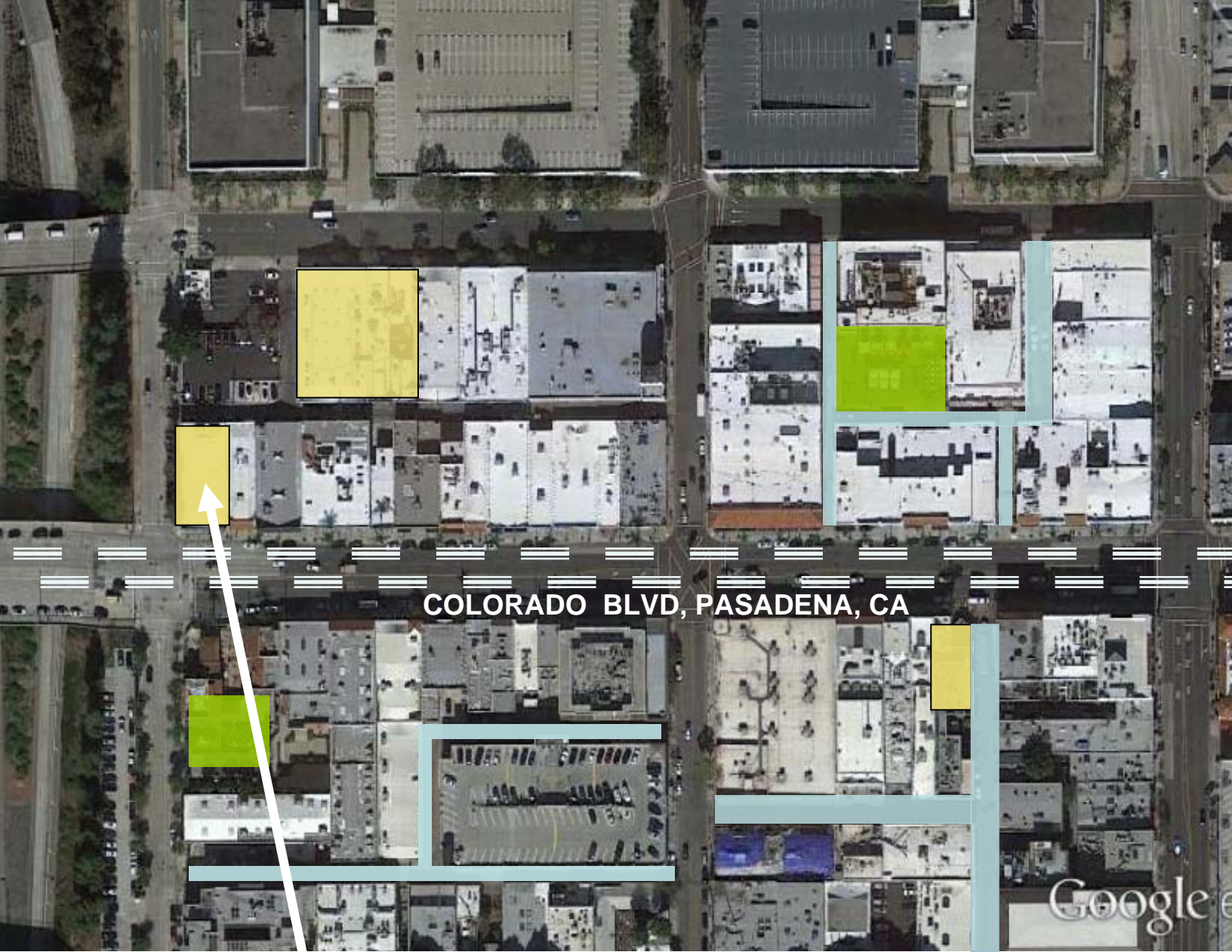

PROGRAMMING
IDENTIFY PROPERTY
BUDGET ANALYSIS
PRELIMINARY PLANNING

LEASE SPACE ANALYSIS
6,500 sf

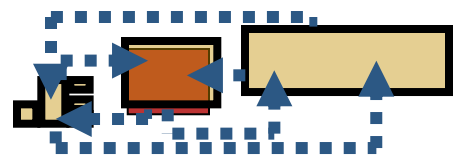

PHASE II
LEASE SPACE IMPROVEMENTS

PROJECT LE³

PASADENA LEARN Shops - MENTOR Scheduling

OPTION A Alternate week attendance for HS & MS Mentor

Mon	Tues	Wed	Th	Fri	
10 HS	10 HS	10 HS	10 HS	10 HS	50 HS MTRs
10 MS	10 MS	10 MS	10 MS	10 MS	50 MS MTRs
20 Mentors per 1/2 day session					
10 HS	10 HS	10 HS	10 HS	10 HS	50 HS MTRs
10 MS	10 MS	10 MS	10 MS	10 MS	50 MS MTRs
20 Mentors - 1/2 Session					
40 Mentors/day					
200 Mentors/week					

1/2 Day Learn Shops
 100 HS Mentors week *alternate weeks attendance*
 100 MS Mentors week *alternate weeks attendance*
206 Total HS Teachers/District
175 Total MS Teachers/District

OPTION B Weekly attendance for HS & MS Mentors

Mon	Tues	Wed	Th	Fri	
20 HS	20 HS	20 HS	20 HS	20 HS	100 HS MTRs
20 MS	20 MS	20 MS	20 MS	20 MS	100 MS MTRs
40 Mentors per 1/2 day session					
20 HS	20 HS	20 HS	20 HS	20 HS	100 HS MTRs
20 MS	20 MS	20 MS	20 MS	20 MS	100 MS MTRs
40 Mentors - 1/2 Session					
80 Mentors/day					
400 Mentors/week					

1/2 Day Learn Shops
 200 HS Mentors *every week*
 200 MS Mentors *every week*

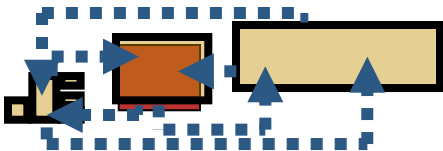

**PHASE II
LEASE SPACE IMPROVEMENTS**

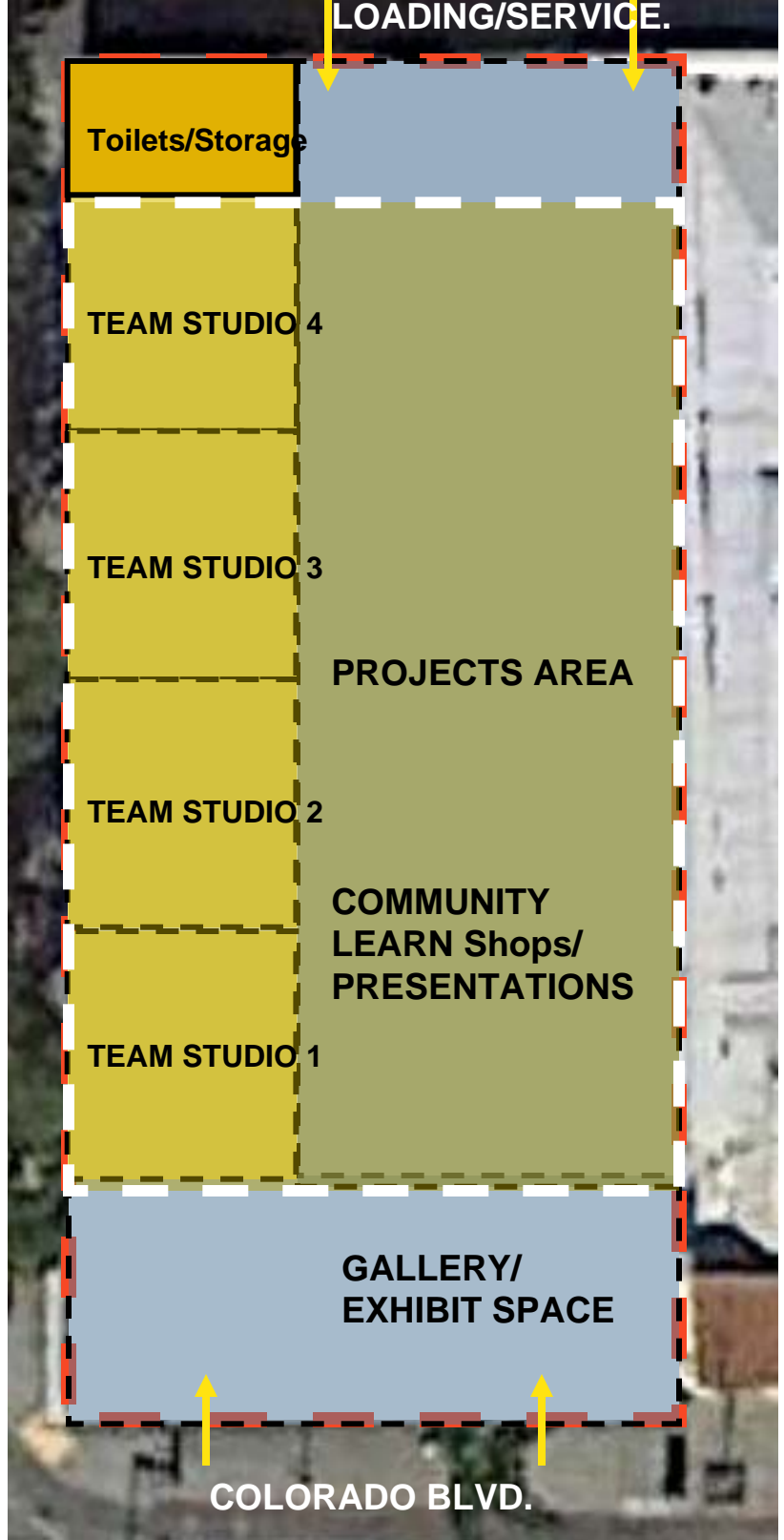

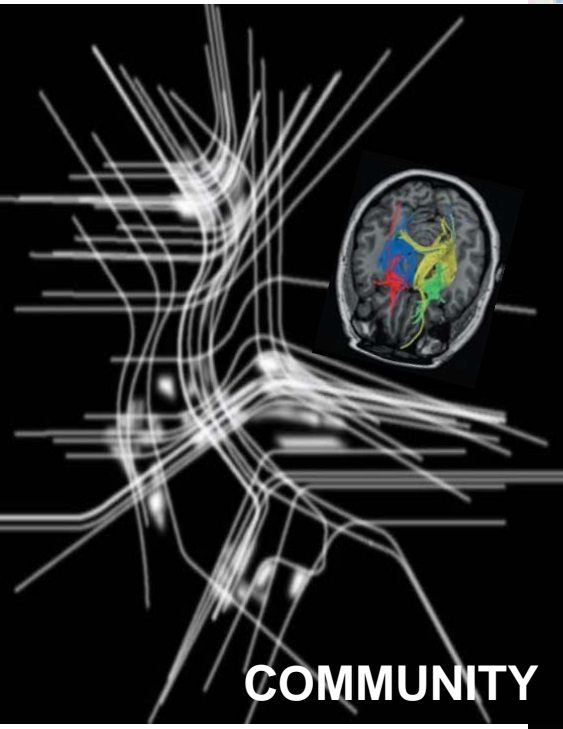

COMMUNITY INTREGRATION



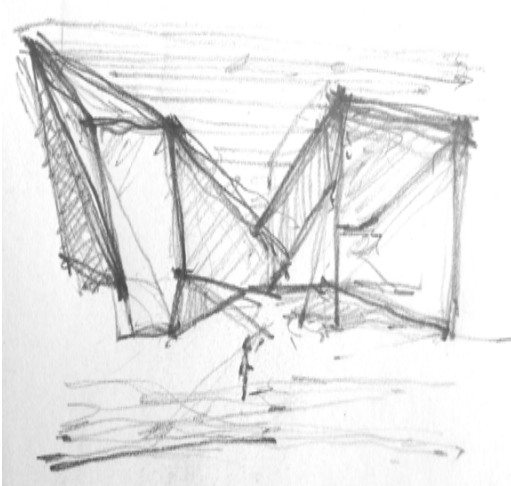
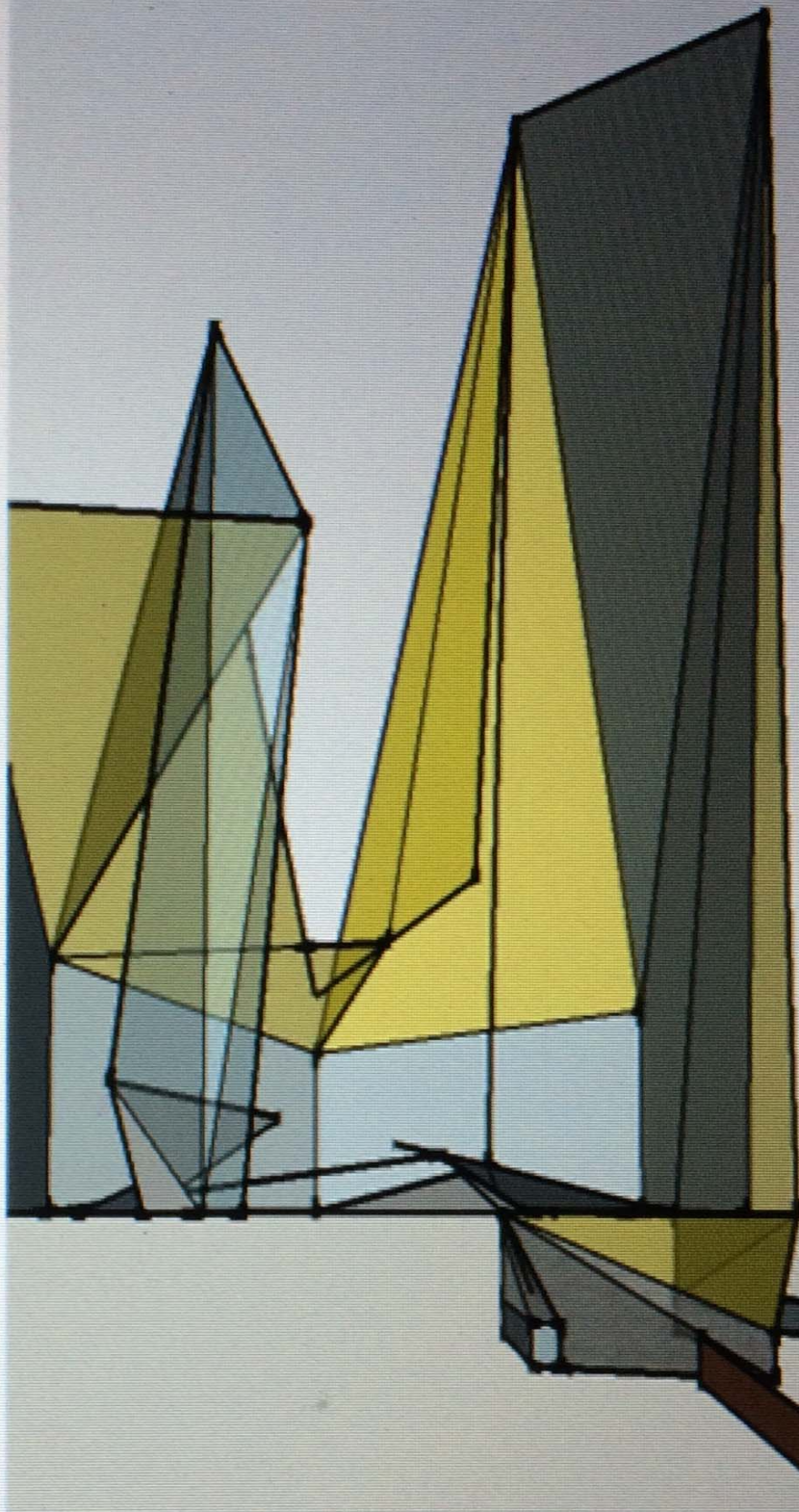
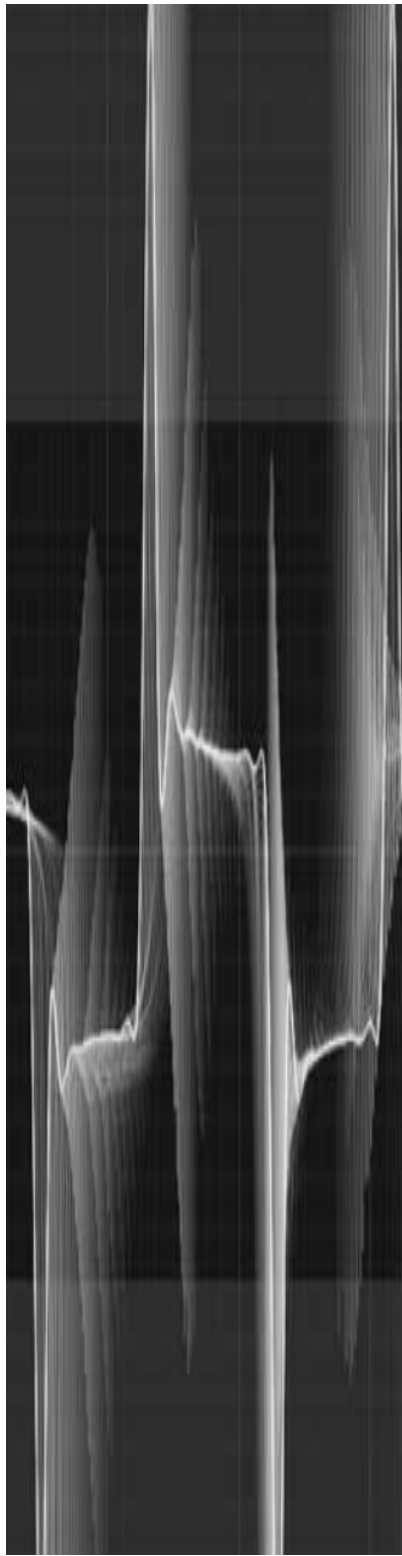

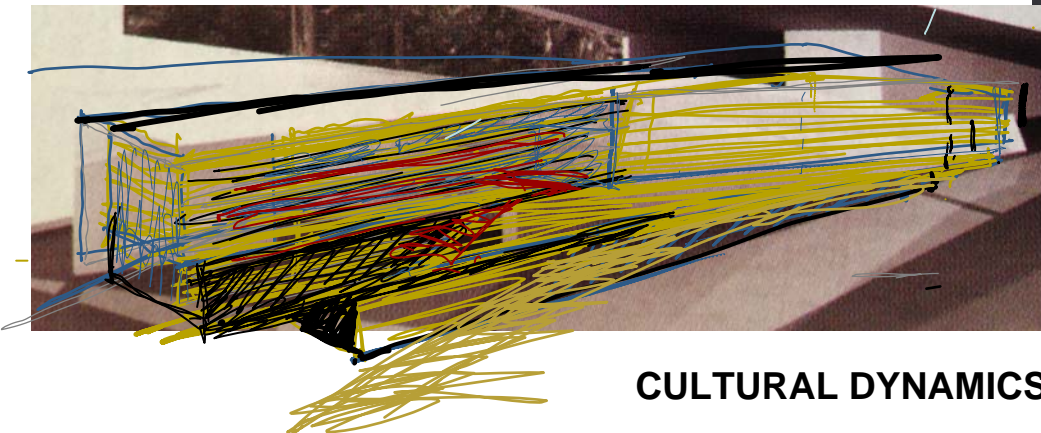

CULTURAL DYNAMICS

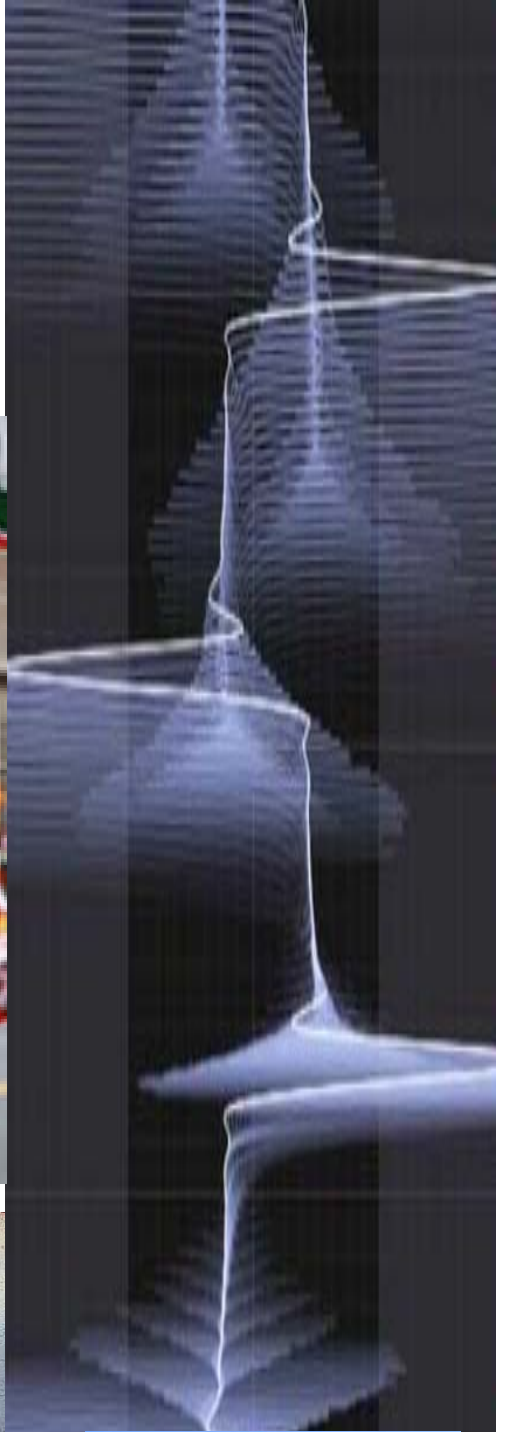

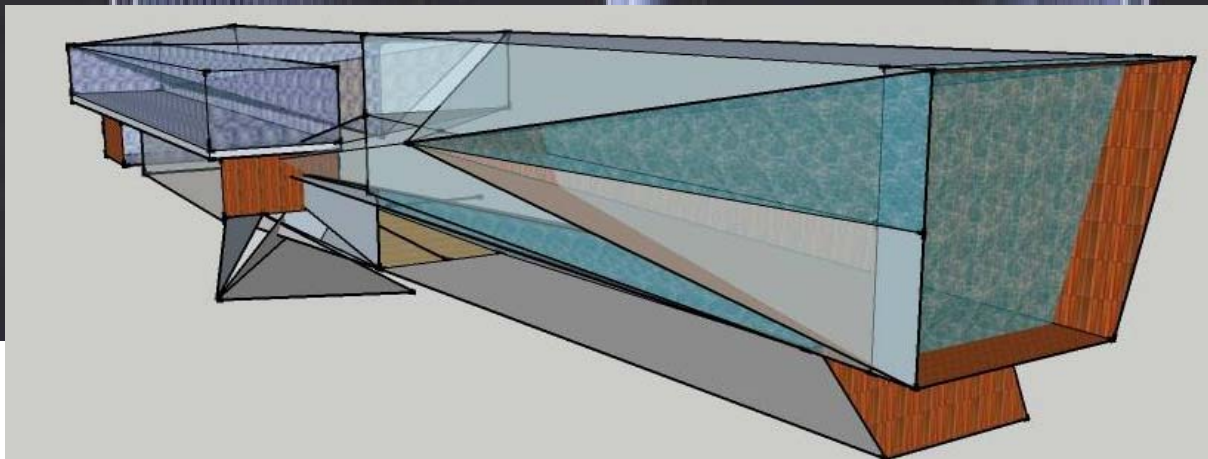
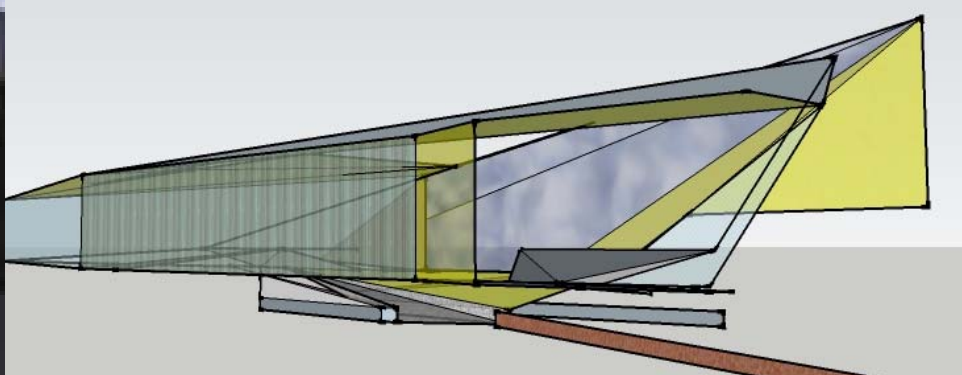

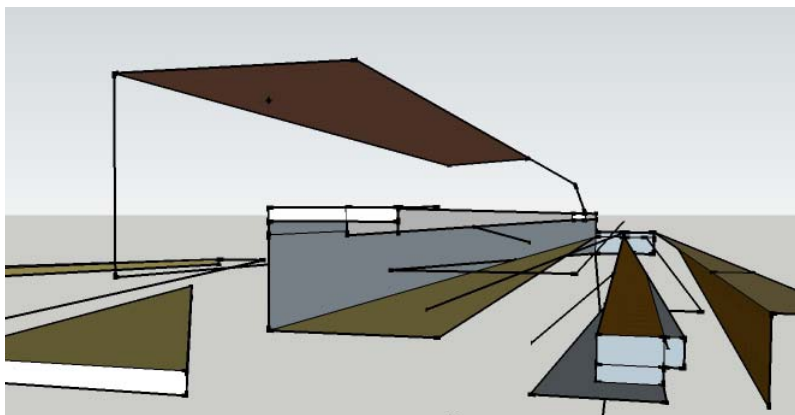
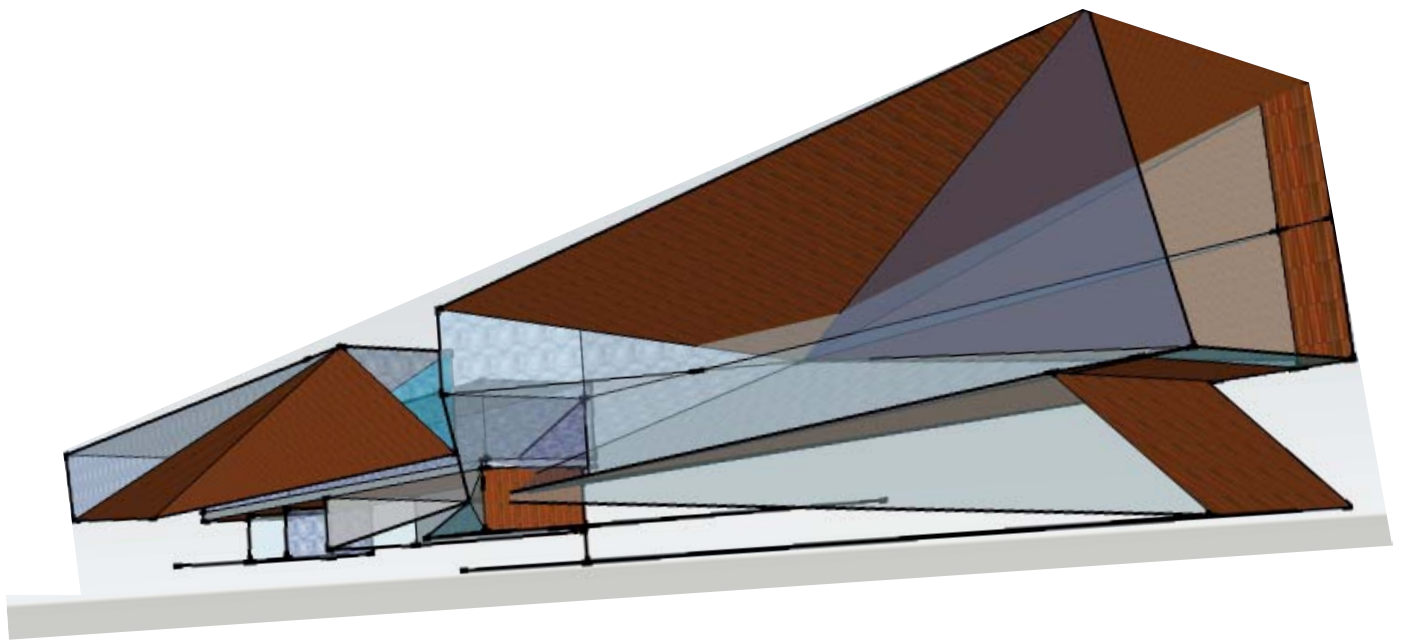
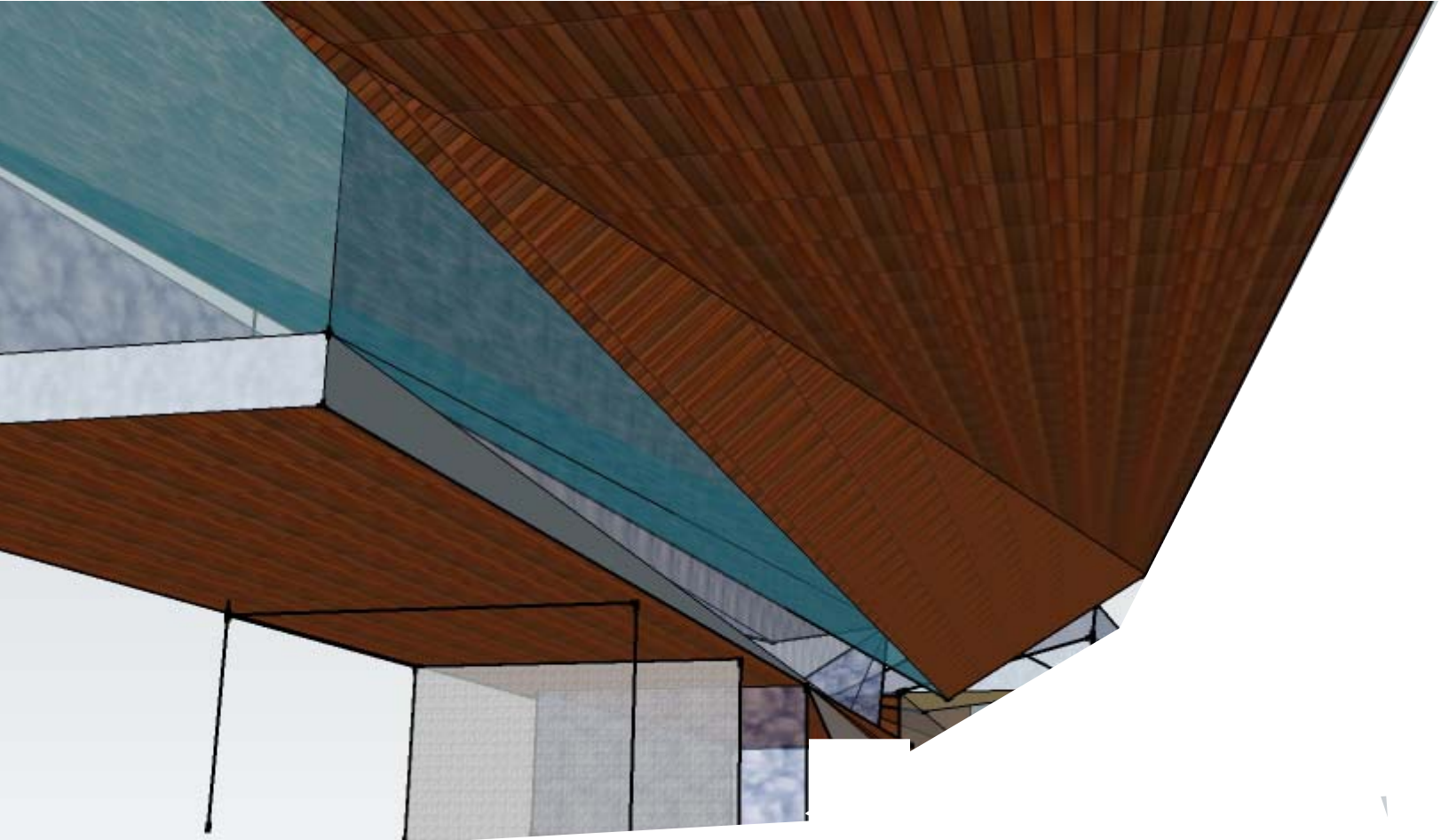

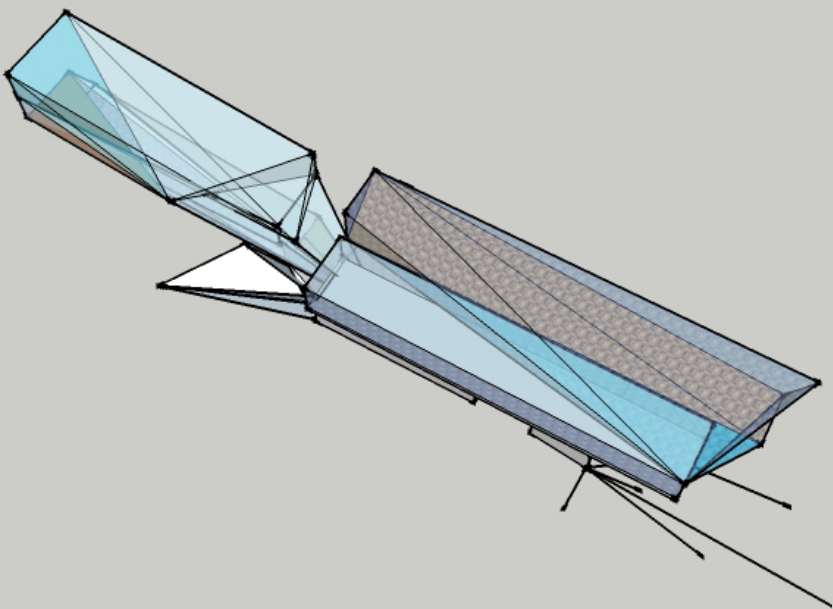
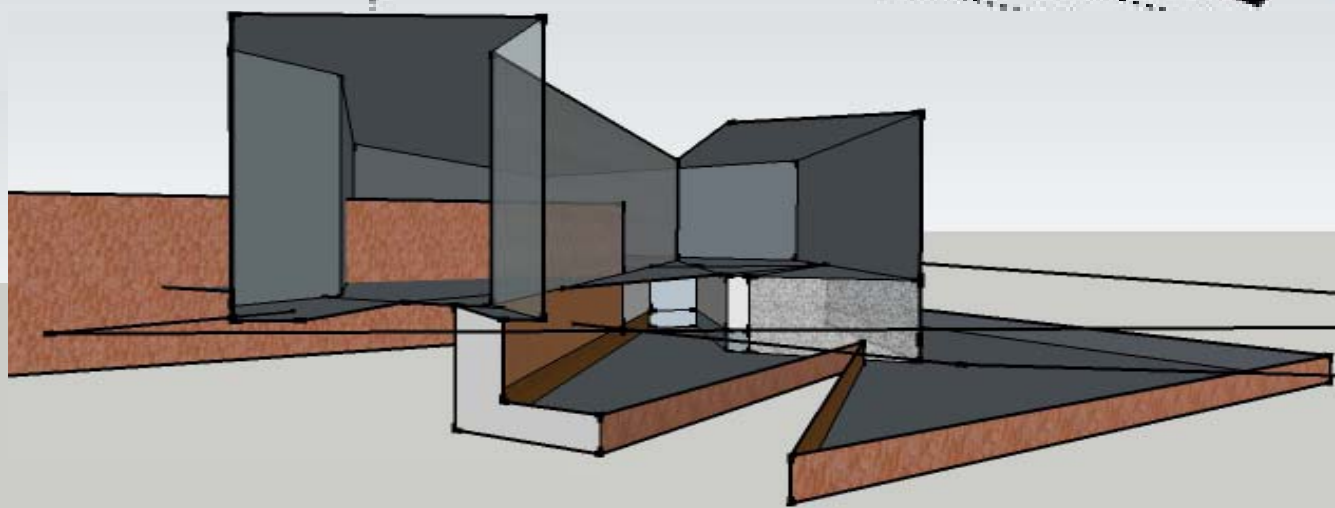
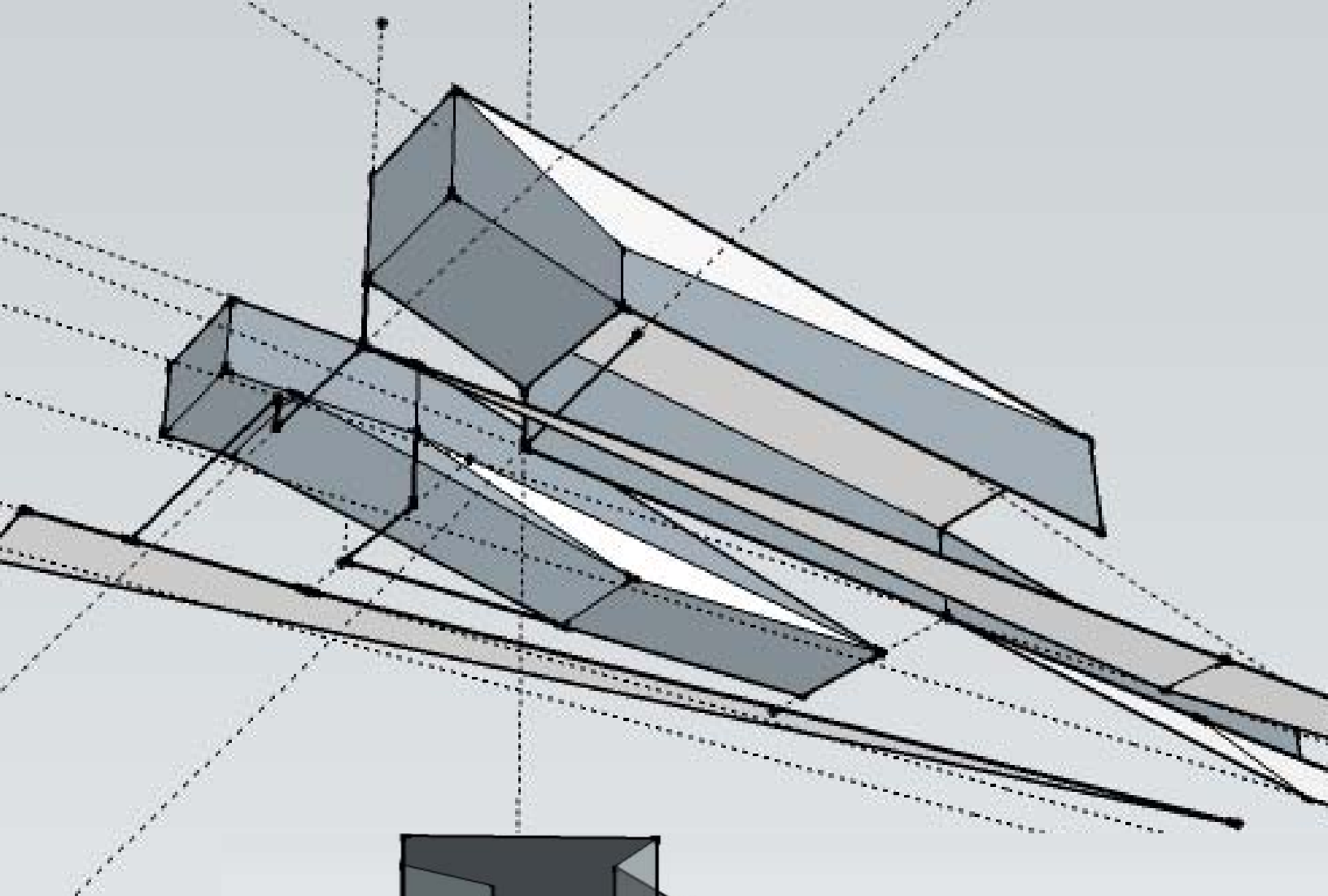

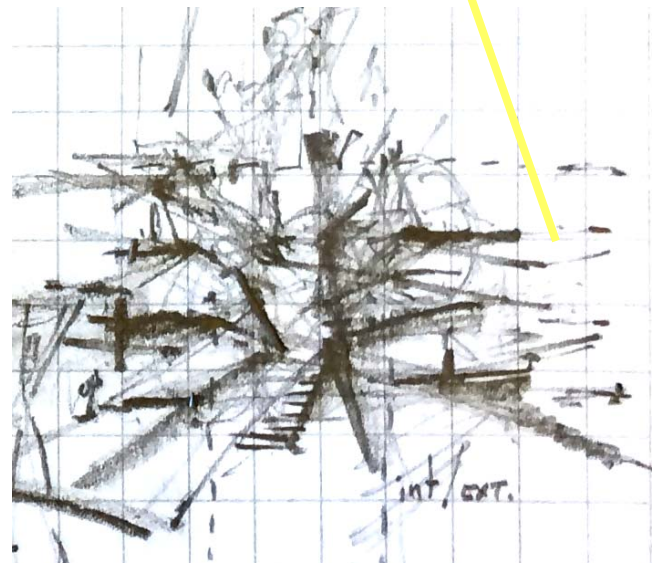
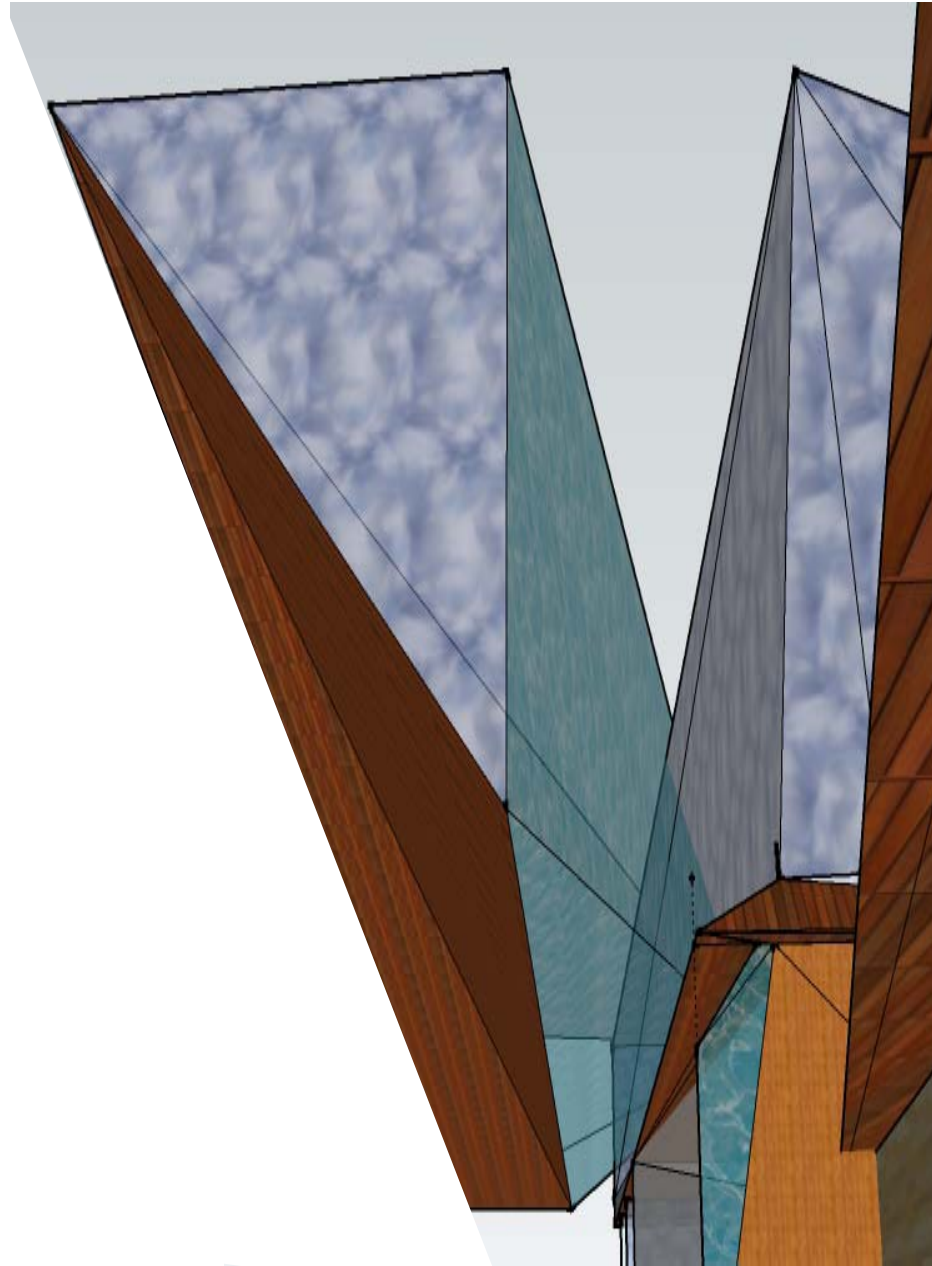

2D MURAL SPATIAL translation

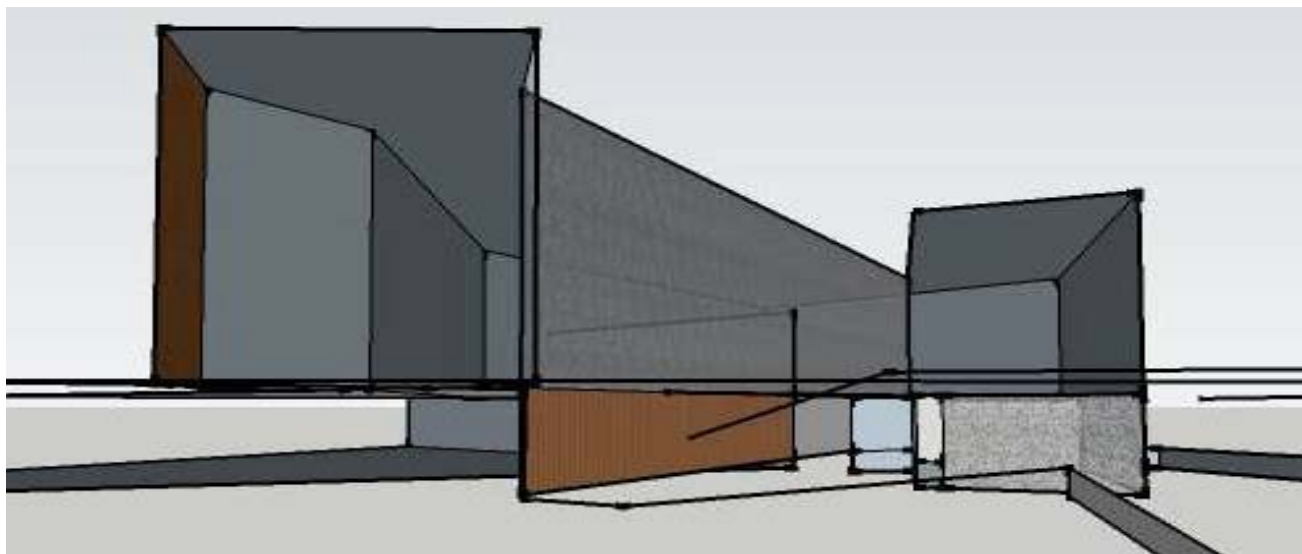
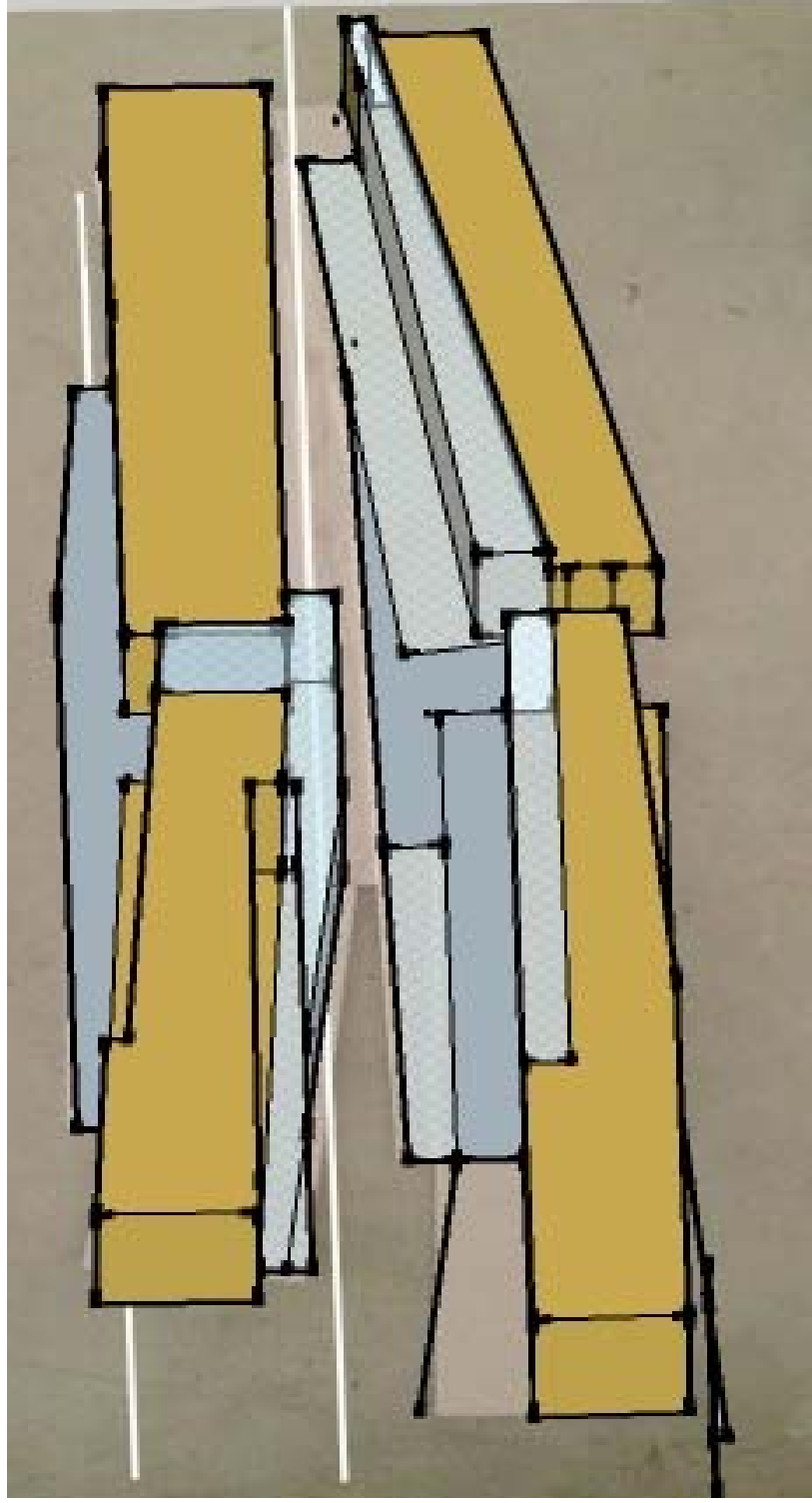
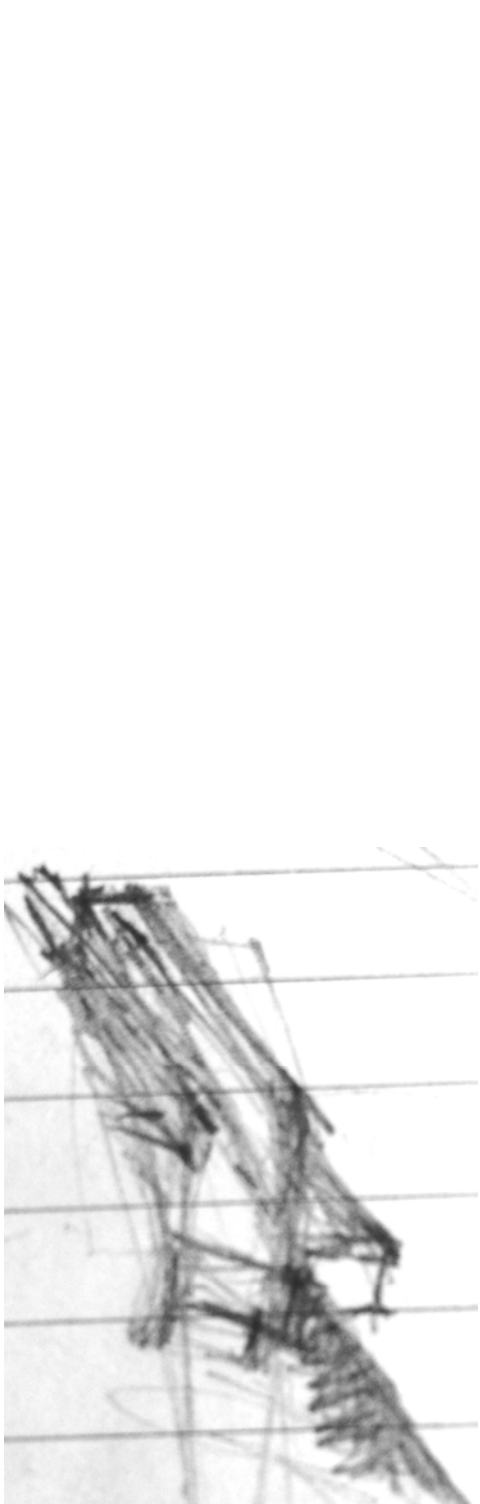

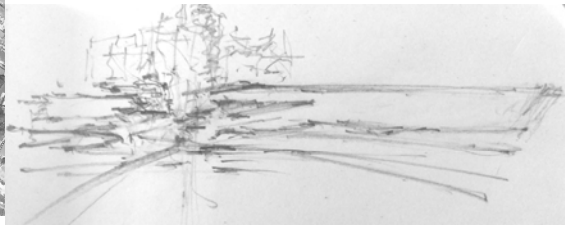
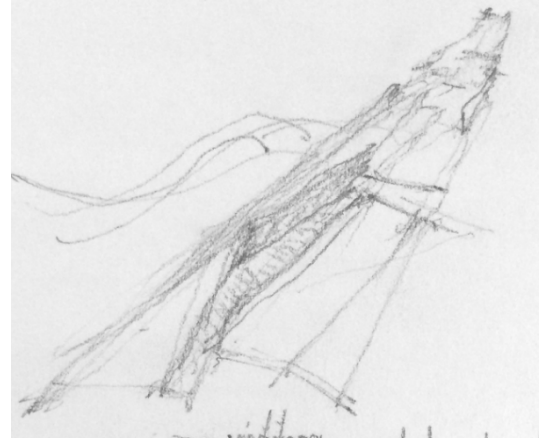
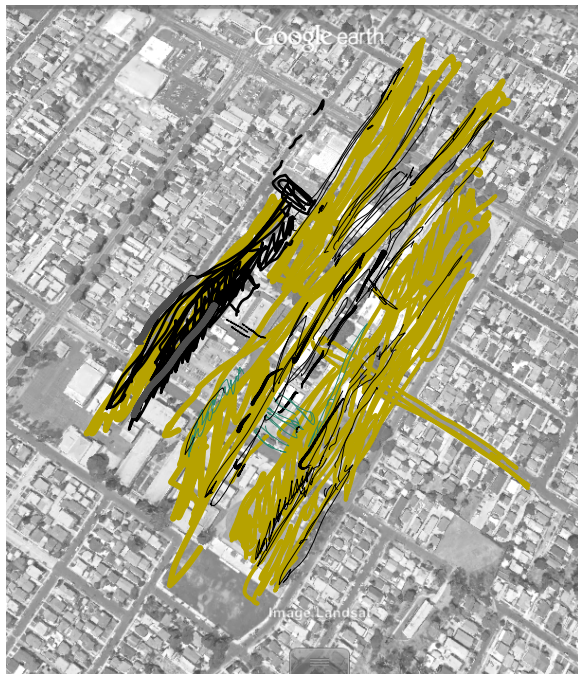
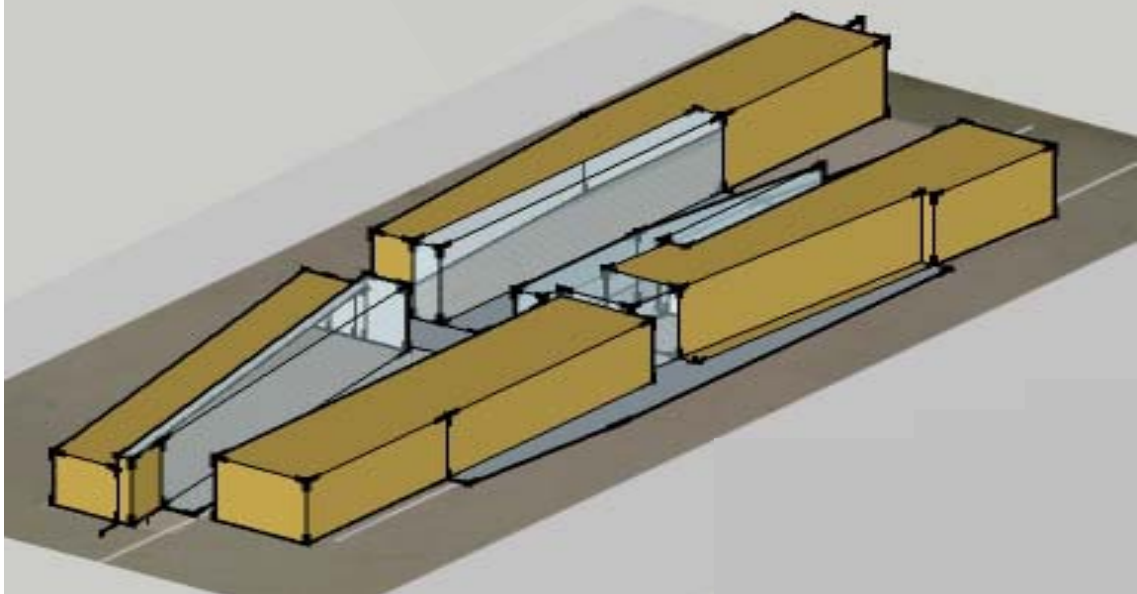
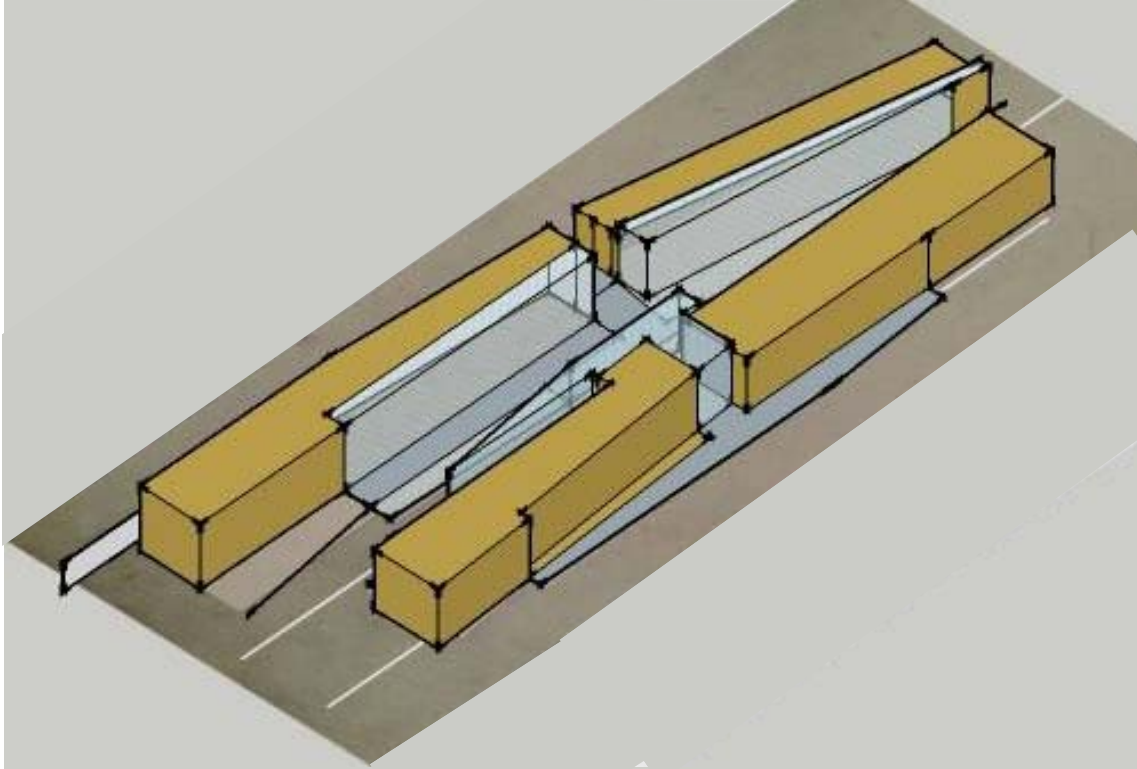

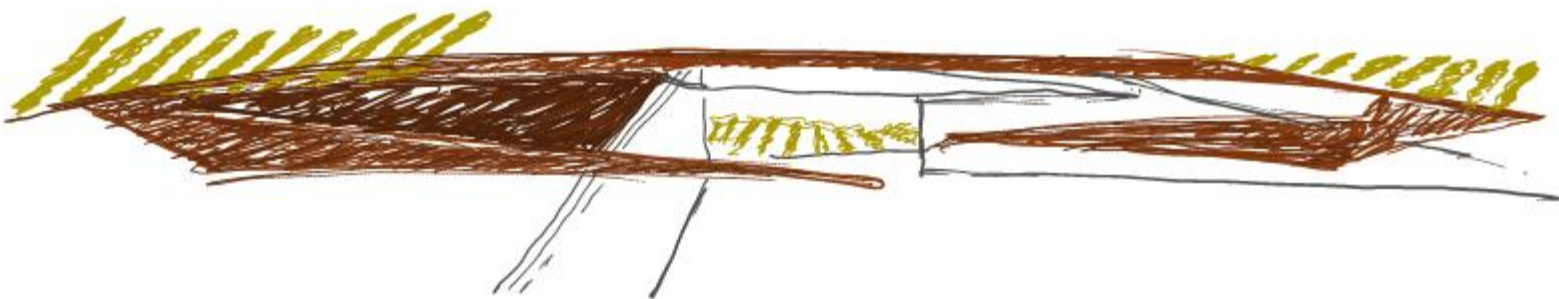
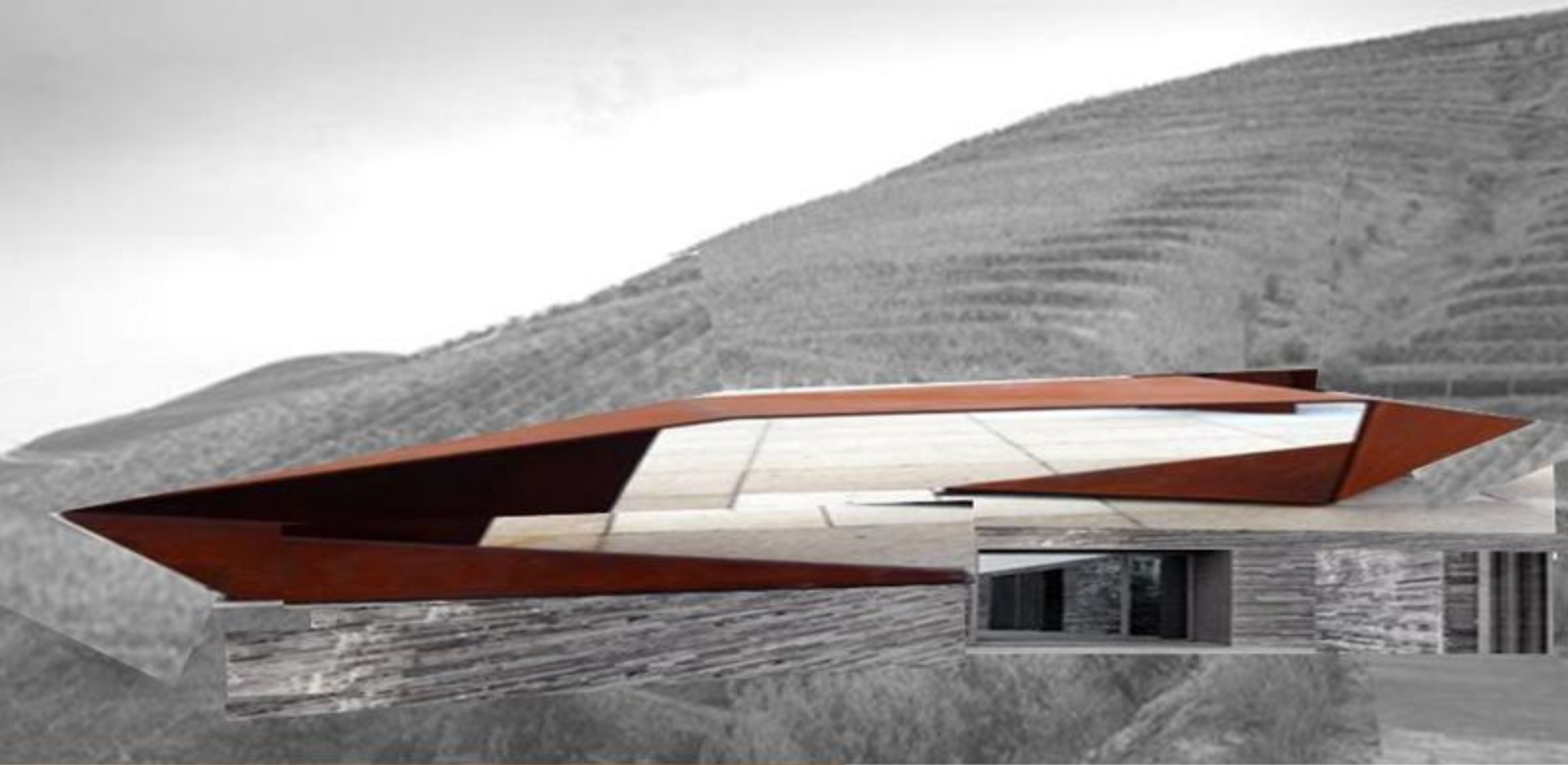

new WINERY